

SECTION 3 - ENGINE/TRANSMISSION

TABLE OF CONTENTS

Engine/Transmission	3-2
Specifications	3-2
Table of Contents (Removing/Disassembling/ Assembling/Installing)	3-3
Table of Contents (Servicing Components)	3-15



Engine/Transmission

This section has been organized into sub-sections which show a progression for the complete servicing of the Arctic Cat ATV engine/transmission.

To service the center crankcase halves, the engine/transmission must be removed from the frame.

To service top-side, left-side, and right-side components, the engine/transmission does not have to be removed from the frame.

NOTE: Arctic Cat recommends the use of new gaskets, lock nuts, and seals and lubricating all internal components when servicing the engine/transmission.

NOTE: Some photographs and illustrations used in this section are used for clarity purposes only and are not designed to depict actual conditions.

Specifications*

VALVES AND GUIDES		
Valve Face Diameter	(intake) (exhaust)	36 mm (1.4 in.) 29 mm (1.1 in.)
Valve/Tappet Clearance (cold engine)	(intake) (exhaust)	0.10-0.20 mm (0.0039-0.0078 in.) 0.20-0.30 mm (0.0078-0.0118 in.)
Valve Guide/Stem Clearance	(intake) (exhaust)	0.010-0.037 mm (0.0004-0.0015 in.) 0.030-0.057 mm (0.0012-0.0024 in.)
Valve Guide/Valve Stem Deflection (wobble method)	(max)	0.35 mm (0.014 in.)
Valve Guide Inside Diameter		5.000-5.012 mm (0.1968-0.1973 in.)
Valve Stem Outside Diameter	(intake) (exhaust)	4.975-4.990 mm (0.1959-0.1965 in.) 4.955-4.970 mm (0.1951-0.1957 in.)
Valve Stem Runout	(max)	0.05 mm (0.002 in.)
Valve Head Thickness	(min)	0.5 mm (0.02 in.)
Valve Face/Seat Width		0.9-1.1 mm (0.035-0.043 in.)
Valve Seat Angle	(intake) (exhaust)	45° 45°
Valve Face Radial Runout	(max)	0.03 mm (0.001 in.)
Valve Spring Free Length	(max)	38.8 mm (1.53 in.)
Valve Spring Tension @ 36.0 mm (1.42 in.)		18.6-21.4 kg (41.0-47.2 lb)

CAMSHAFT AND CYLINDER HEAD		
Cam Lobe Height (min)	(intake) (exhaust)	36.020 mm (1.418 in.) 34.900 mm (1.374 in.)
Camshaft Journal Oil Clearance	(max)	0.15 mm (0.0059 in.)
Camshaft Journal Holder Inside Diameter		22.012-22.025 mm (0.8666-0.8671 in.)
Camshaft Journal Outside Diameter		21.972-21.993 mm (0.8650-0.8658 in.)
Camshaft Runout	(max)	0.10 mm (0.004 in.)
Cylinder Head Distortion	(max)	0.05 mm (0.002 in.)
Cylinder Head Cover Distortion	(max)	0.05 mm (0.002 in.)

CYLINDER, PISTON, AND RINGS		
Piston Skirt/Cylinder Clearance	(max)	0.12 mm (0.0047 in.)
Cylinder Bore	(max)	90.015 mm (3.544 in.)
Piston Diameter 15 mm (0.60 in.) from Skirt End		89.965-89.950 mm (3.5419-3.5425 in.)
Bore x Stroke		90.0 x 62.6 mm (3.54 x 2.46 in.)
Cylinder Trueness	(max)	0.05 mm (0.002 in.)
Piston Ring End Gap - Installed (both)		0.08-0.20 mm (0.003-0.008 in.)
Piston Ring to Groove Clearance (max)	(1st) (2nd)	0.180 mm (0.0071 in.) 0.150 mm (0.0059 in.)
Piston Ring Groove Width	(1st) (2nd) (oil)	0.78-0.80 mm (0.0307-0.0315 in.) 1.30-1.32 mm (0.0319-0.0327 in.) 2.01-2.03 mm (0.079-0.080 in.)
Piston Ring Thickness	(1st) (2nd)	1.08-1.10 mm (0.0425-0.0433 in.) 0.77-0.79 mm (0.0303-0.0311 in.)
Piston-Pin Bore		20.002-20.008 mm (0.7875-0.7877 in.)
Piston-Pin Outside Diameter		19.995-20.000 mm (0.7872-0.7874 in.)

CRANKSHAFT		
Connecting Rod (small end inside diameter)	(max)	20.040 mm (0.7890 in.)
Connecting Rod (big end side-to-side)		0.30-0.65 mm (0.012-0.026 in.)
Connecting Rod (big end width)		21.95-22.00 mm (0.864-0.866 in.)
Connecting Rod (small end deflection)	(max)	3 mm (0.12 in.)
Crankshaft (web-to-web)		61.9-62.1 mm (2.437-2.448 in.)
Crankshaft Runout (max)		0.08 mm (0.003 in.)
Oil Pressure at 60°C (140°F) @ 3000 RPM	(above) (below)	0.2 kg/cm ² (2.8 psi) 0.6 kg/cm ² (8.5 psi)

CLUTCH	
Clutch Cable Free Play	10-15 mm (0.394-0.591 in.)
Drive Plate (fiber) Thickness (min)	2.62 mm (0.103 in.)
Drive Plate (fiber) Tab (min)	13.2 mm (0.520 in.)
Driven Plate (warpage) (max)	0.1 mm (0.004 in.)
Clutch Spring Length (min)	49.9 mm (1.96 in.)
Primary Reduction Ratio	2.960 (74/25)
Final Reduction Ratio	2.857 (40/14)
Gear Ratios	(1st) 2.538 (33/13) (2nd) 1.666 (30/18) (3rd) 1.238 (26/21) (4th) 1.000 (23/23) (5th) 0.846 (22/26) (reverse) 2.153 (28/13)
Engine Fork To Groove (side clearance)	0.10-0.30 mm (0.004-0.012 in.)
Reverse Fork to Groove (side clearance)	0.10-0.50 mm (0.004-0.020 in.)
Shift Fork Groove Width (#1, #2, & #3)	5.0-5.1 mm (0.197-0.201 in.)
Shift Fork Thickness (#1, #2, & #3)	4.8-4.9 mm (0.189-0.193 in.)
Engine Coolant Fan Thermo-Switch Operating Temperature (off→on) (on→off)	88°C (190°F) 82°C (180°F)
Drive Chain	Links 96 20-Pitch Length 319.4 mm (12.57 in.)
Drive Chain Slack	30-40 mm (1.2-1.6 in.)

Table of Contents

(Removing/Disassembling/Assembling/Installing)

Removing Engine/Transmission	3-3
Left-Side Components	3-6
Removing Left-Side Components	3-6
Right-Side Components	3-8
Removing Right-Side Components	3-8
Top-Side Components.....	3-11
Removing Top-Side Components.....	3-11
Center Crankcase Components.....	3-13
Separating Crankcase Halves.....	3-13
Disassembling Crankcase Half	3-14
Servicing Components	3-15
Assembling Crankcase Half	3-33
Joining Crankcase Halves	3-34
Installing Right-Side Components	3-35
Installing Left-Side Components	3-39
Installing Top-Side Components	3-39
Installing Engine/Transmission	3-43

Removing Engine/ Transmission

Many service procedures can be performed without removing the engine/transmission from the frame. Closely observe the note introducing each sub-section for this important information.

👉 AT THIS POINT

If the technician's objective is to service/replace the starter clutch, starter torque limiter, starter, or water pump, the engine/transmission does not have to be removed from the frame.

Secure the ATV on a support stand to elevate the wheels.

⚠️ WARNING

Make sure the ATV is solidly supported on the support stand to avoid injury.

1. Remove the seat.
2. Remove the negative cable from the battery; then remove the positive cable. Remove the battery hold-down; then remove the battery.

⚠️ CAUTION

Battery acid is harmful if it contacts eyes, skin, or clothing. Care must be taken whenever handling a battery.

3. Remove the radiator cap; then drain the engine coolant.
4. Remove the lower engine protective cover (1); then drain the oil from the crankcase.

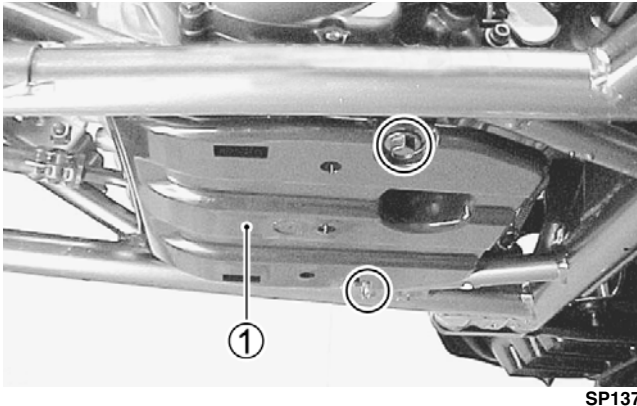

SP137

5. Drain the oil from the oil tank.
6. Remove the gearshift lever (2) and account for the two spacers.
7. Remove the engine oil outlet pipe (3) and the inlet pipe (4); then remove the spacer and O-ring from behind the outlet pipe.

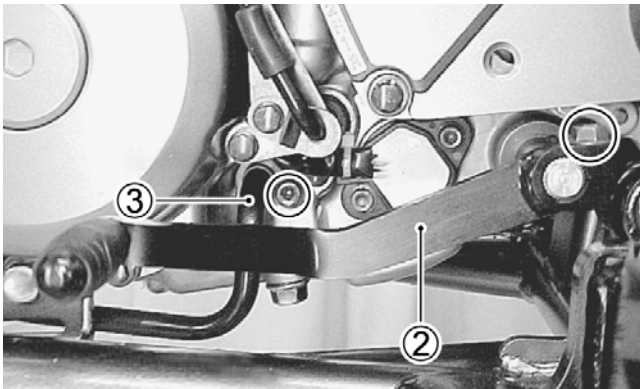

SP138

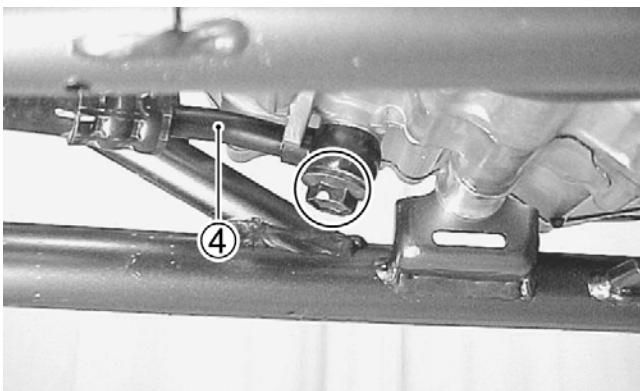

SP139

8. Remove the gas tank (see Section 4).
9. Remove the spark plug cap (1), oil tank overflow hose (2), and the breather hose (3).

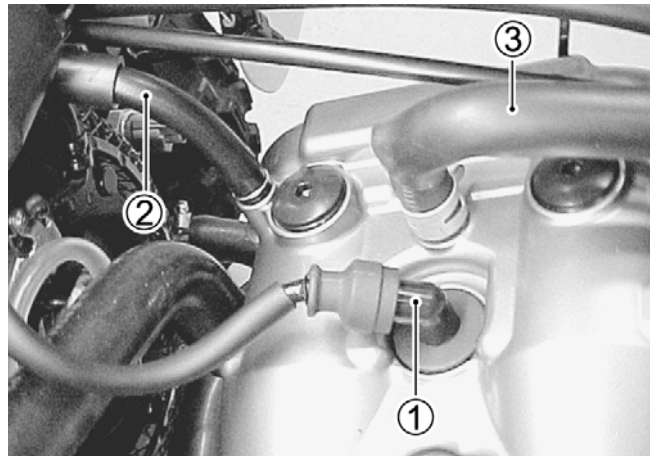

SP140

10. Remove the engine coolant inlet hose (4); then disconnect the coolant outlet hose (5).

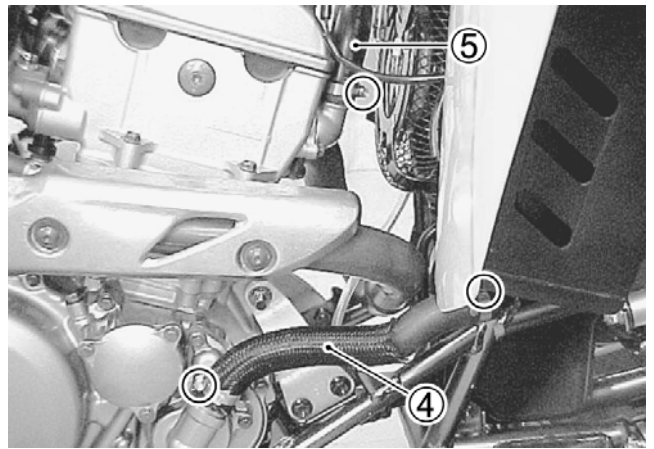

SP141

11. Disconnect the breather hose (6); then remove the oil return tank (7) and the drain-back hose (8).

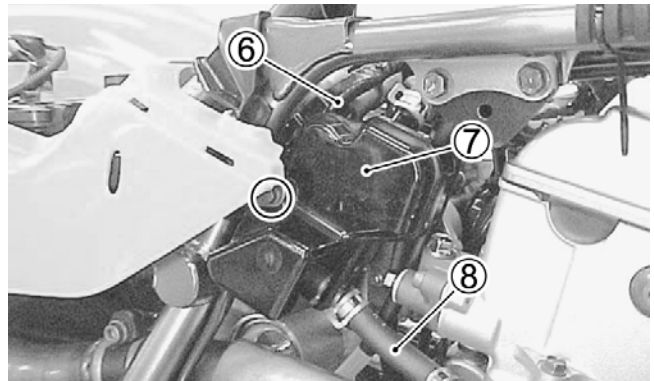

SP142

12. Remove the carburetor leaving the throttle cable and the choke cable attached; then secure the carburetor out of the way sufficiently to enable engine removal.
13. Disconnect the two starter leads from the starter and secure them out of the way.
14. Remove the engine sprocket cover; then remove the engine sprocket with the drive chain.

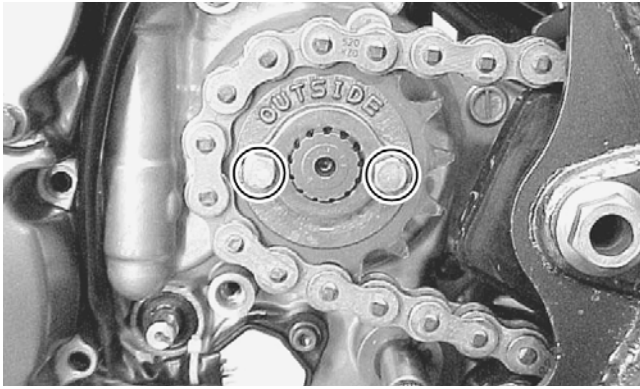

SP143

15. Remove the clutch cable bracket (1); then disconnect the clutch cable (2) from the actuator lever.

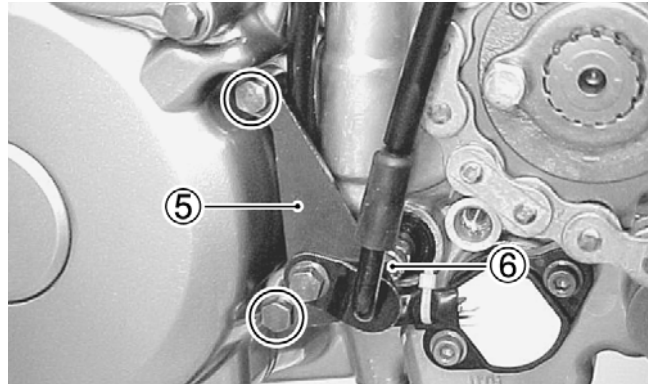

SP146

18. Loosen the muffer clamp bolt (1); then remove the muffer mounting cap screws and the muffer (2).

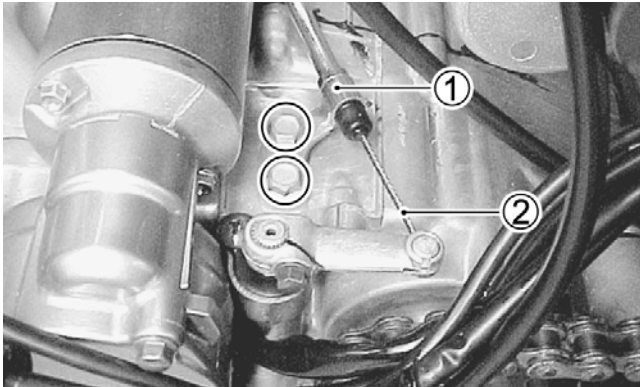

SP144

16. Disconnect the alternator lead wire couplers (3) and the neutral switch lead coupler (4).

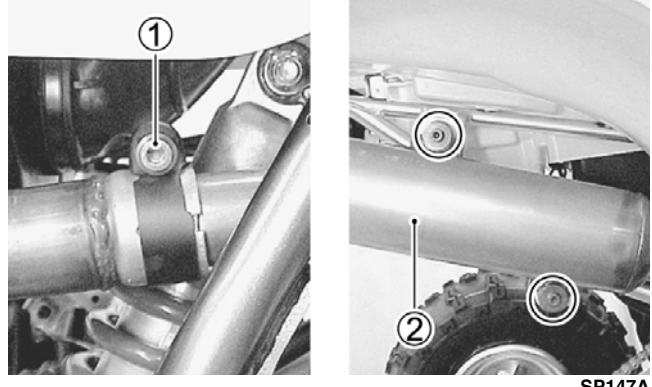

SP147A

19. Remove the lower radiator bolt (3) and swing the bottom of the radiator forward.

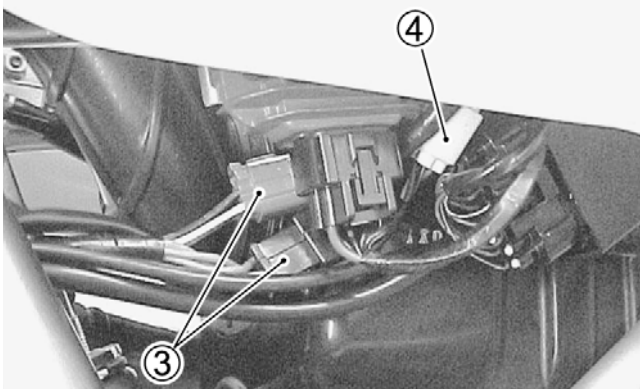

SP145

17. Remove the reverse gear selector cable bracket (5); then disconnect the reverse gear selector cable (6).

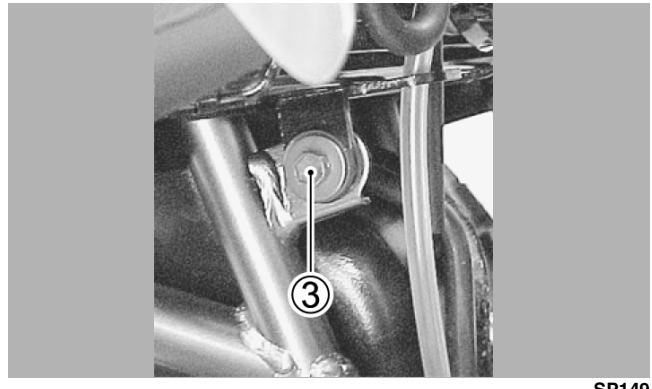

SP149

20. Remove the thermostat cover (4) and thermostat; then remove the exhaust pipe (5).

3

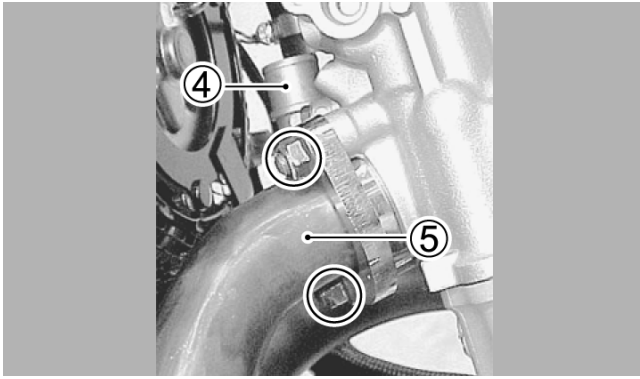

SP150

21. Support the engine with a suitable floor jack; then remove the engine mounting brackets in the following order:
 - A. Upper front: Four cap screws (C), one nut (B), bolt, and two mounting brackets.
 - B. Lower front (not shown): One nut and through bolt directly under the alternator housing.
 - C. Upper rear: Four cap screws (C), through-bolt (A) with nut, and one mounting bracket.
 - D. Lower rear: One nut (B) and through-bolt leaving two collars (D) in the frame.

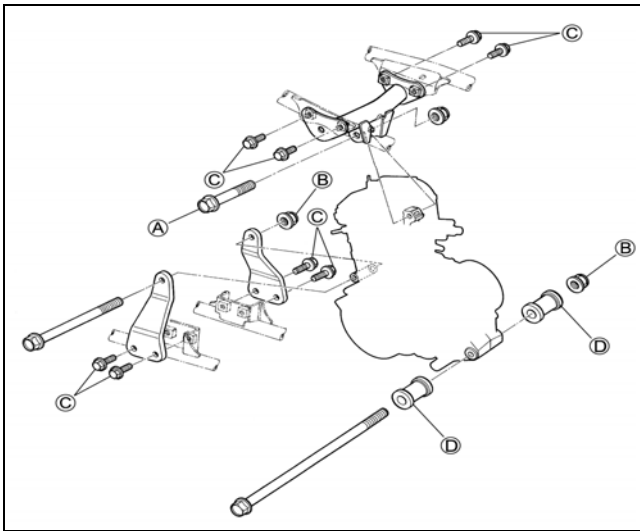

ATV2158

22. Work the engine forward to clear the swing-arm; then remove the engine assembly from the left-side of the frame.

Left-Side Components

■ **NOTE:** For efficiency, it is preferable to remove and disassemble only those components which need to be addressed and to service only those components. The technician should use discretion and sound judgment.

AT THIS POINT

To service any one specific component, only limited disassembly of components may be necessary. Note the AT THIS POINT information in each sub-section.

■ **NOTE:** The engine/transmission does not have to be removed from the frame for this procedure.

Removing Left-Side Components

- A. Cover**
- B. Drive Gear**
- C. Rotor/Flywheel**
- D. Neutral Switch**

1. Remove the cap screws securing the starter drive cover; then remove the cover and drive gear. Account for two thrust washers and the large O-ring.

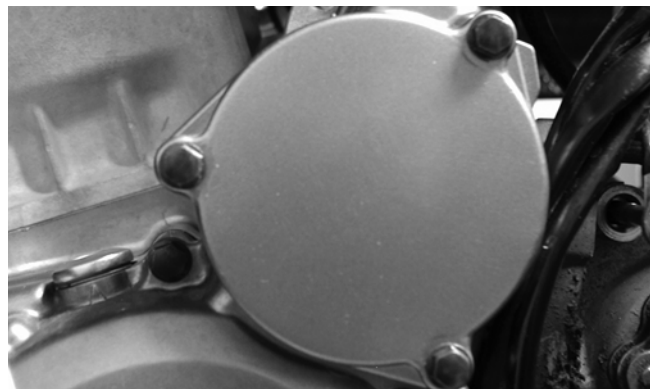

SP058

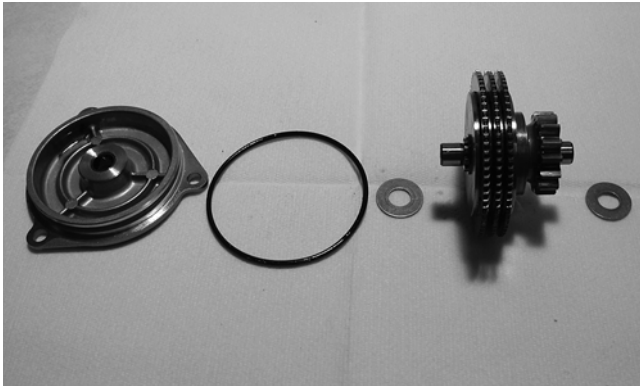

SP060

- Remove the cap screws securing the rotor/flywheel cover; then remove the cover.

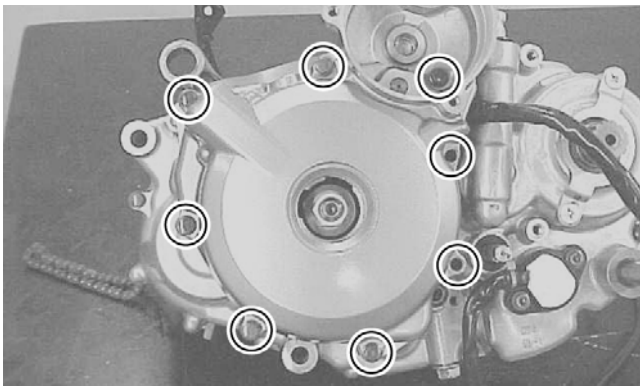

SP151

- Remove the starter driven gear (2), two alignment pins (3), and the cover gasket (4). Account for two thrust washers from the driven gear.

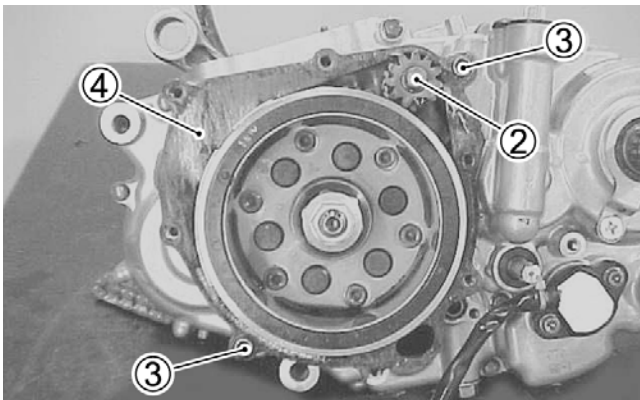

SP152

■ **NOTE:** If the right-side components are to be removed, do not remove the rotor/flywheel. Proceed to step 7.

- Using a 27 mm offset box-end wrench, hold the rotor/flywheel; then remove the nut securing the rotor/flywheel to the crankshaft.

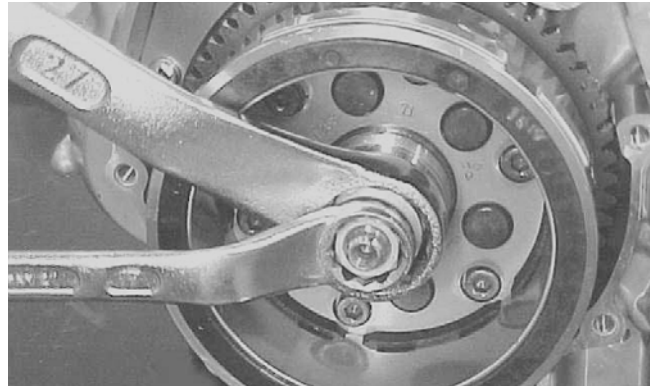

SP153

- Using an appropriate magneto rotor remover, remove the rotor/flywheel assembly from the crankshaft.

- Remove the key (3); then remove the starter driven gear (4).

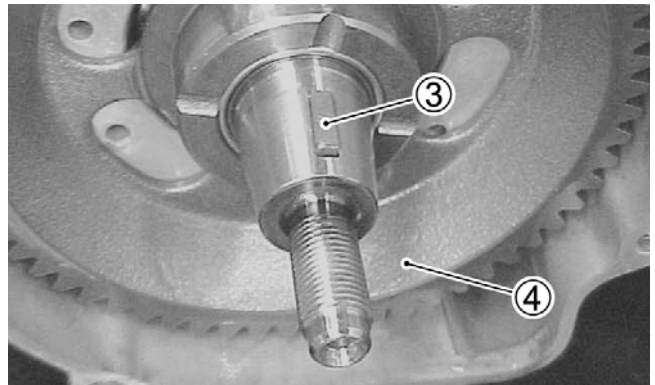

SP154

- Remove the Allen-head cap screws securing the neutral switch housing (1); then remove the switch. Account for one O-ring (2), two switch contacts (3 and 4), and the two springs behind the switch contacts.

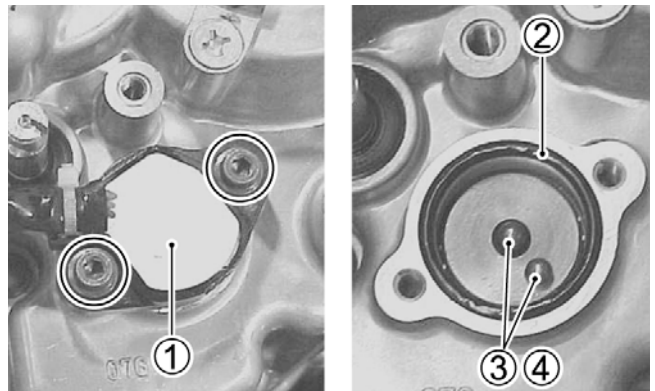

SP175A

■ **NOTE:** To aid in installing, it is recommended that the assemblies be kept together and **IN ORDER.**

3

Right-Side Components

■ **NOTE:** For efficiency, it is preferable to remove and disassemble only those components which need to be addressed and to service only those components. The technician should use discretion and sound judgment.

 **AT THIS POINT**

To service any one specific component, only limited disassembly of components may be necessary. Note the AT THIS POINT information in each sub-section.

■ **NOTE:** The engine/transmission does not have to be removed from the frame for this procedure.

Removing Right-Side Components

- A. Clutch Cover**
- B. Clutch Sleeve Hub Assembly**
- C. Primary Driven Gear Assembly**
- D. Oil Pump Idler Gear and Driven Gear**
- E. Oil Pump**
- F. Shift Shaft**
- G. Shift Cam Driven Gear**
- H. Balancer Driven Gear and Drive Gear**
- I. Neutral Switch**

1. Remove the cap screws securing the clutch cover to the crankcase noting the position of the cap screw with a sealing washer (A).

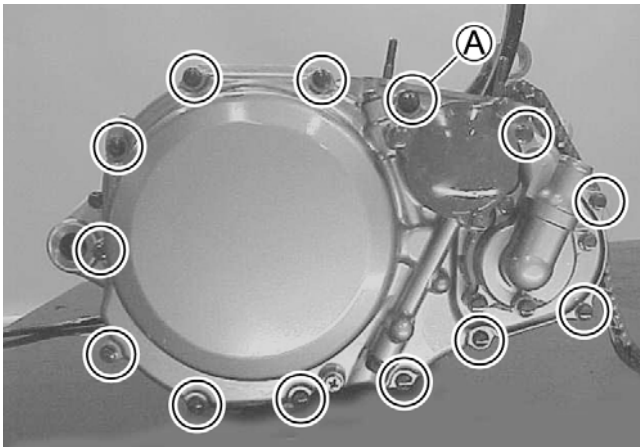

SP155

2. Remove the alignment pins (5) and the gasket (6).

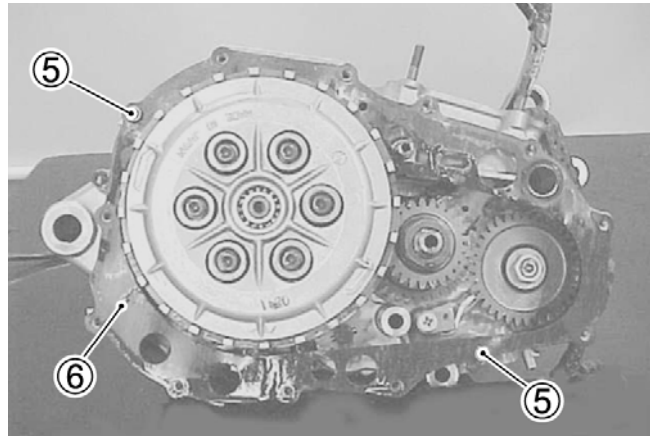

SP156

3. Hold the rotor/flywheel nut using a 27 mm offset wrench; then working diagonally, remove the clutch bolt and springs.

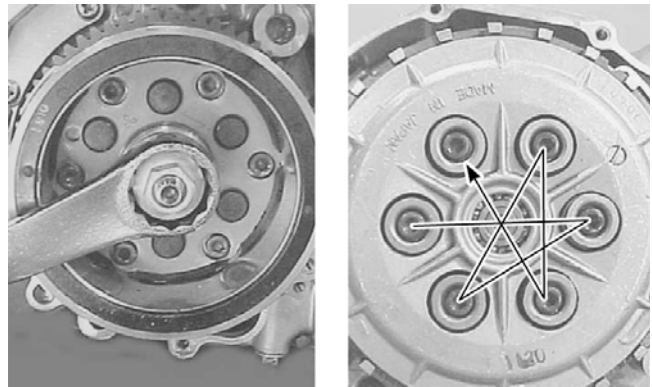

SP157A

4. Remove the clutch pressure disc; then remove the clutch drive and driven plates.
5. Remove the clutch release pin (1) and the push rod (2); then flatten the clutch sleeve hub washer (3).

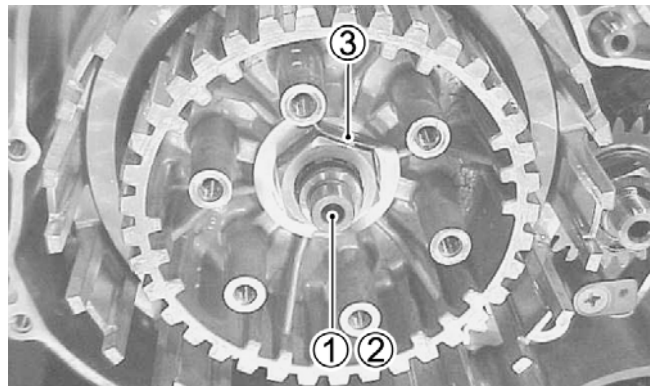

SP159

6. Using an appropriate clutch sleeve hub holder, secure the clutch sleeve hub and remove the hub nut; then remove the clutch sleeve hub.

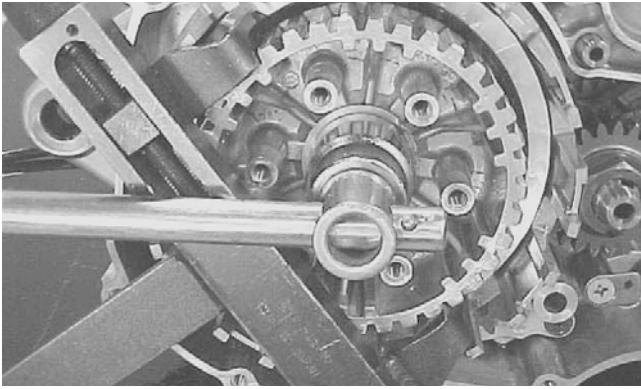

SP160

7. Remove the primary driven gear assembly (1) and the washer (2); then remove the collar (3).

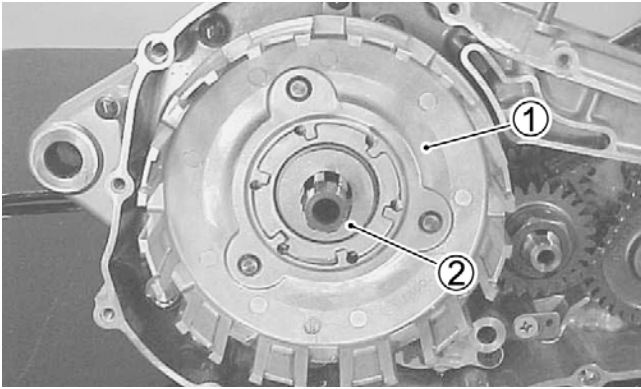

SP161

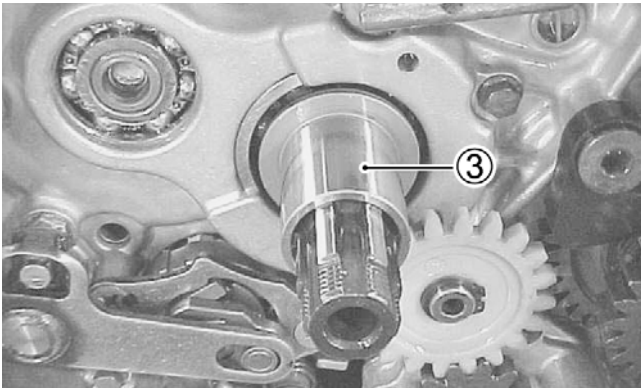

SP162

8. Remove the cam chain tensioner (4) and the cam chain (5); then remove the oil pipe (6).

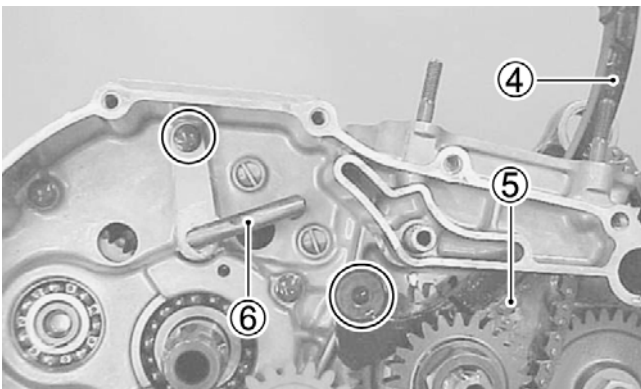

SP163

■ **NOTE:** If the top-side components have not been removed, the tensioner and cam chain cannot be removed.

9. Remove the oil pump idler gear (7), the oil pump driven gear (8), and the oil pump drive pin (9); then remove the screws securing the oil pump.

■ **NOTE:** Do not remove the circlip (A) before separating the crankcase halves to prevent the idler shaft from falling into the crankcase.

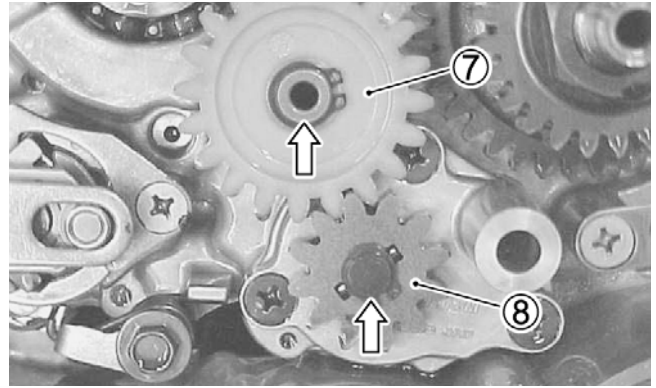

SP164

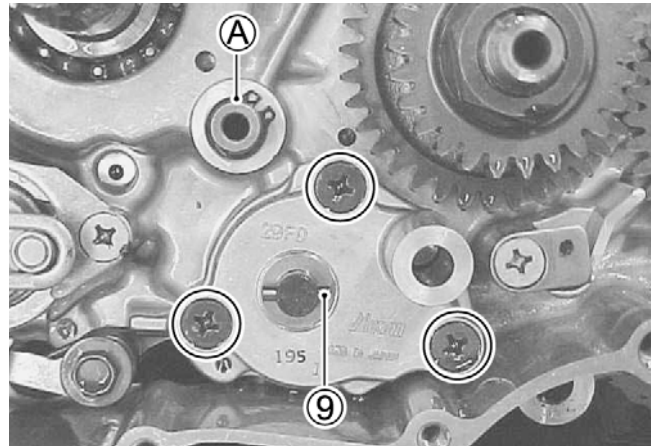

SP165

10. Remove the circlip (2) from the left side of the shift shaft; then remove the shift shaft (1).

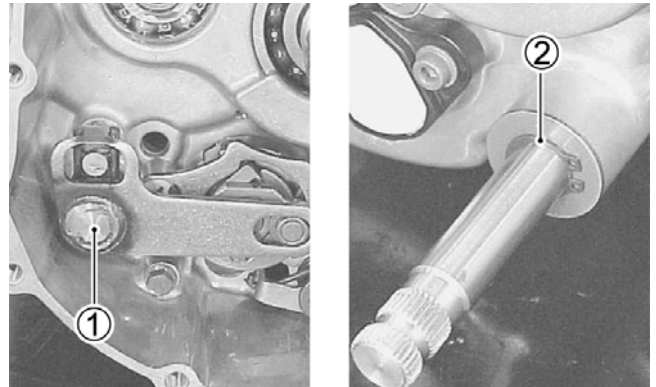

SP166A

11. Remove the two screws securing the shift pawl lifter (3) and the shift cam driven gear (4). Remove the shift cam stopper arm (5).

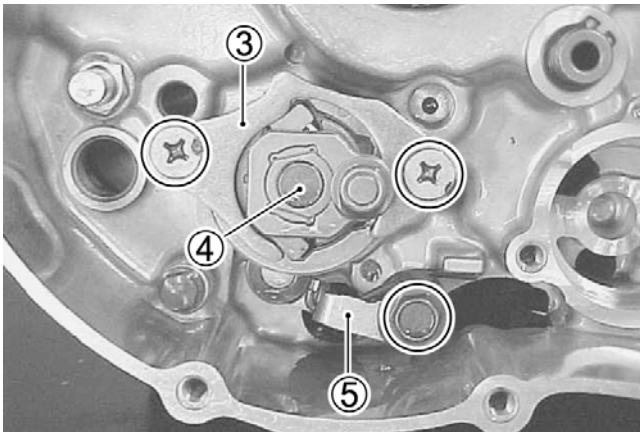

SP168

12. Remove the shift cam driven gear bolt.

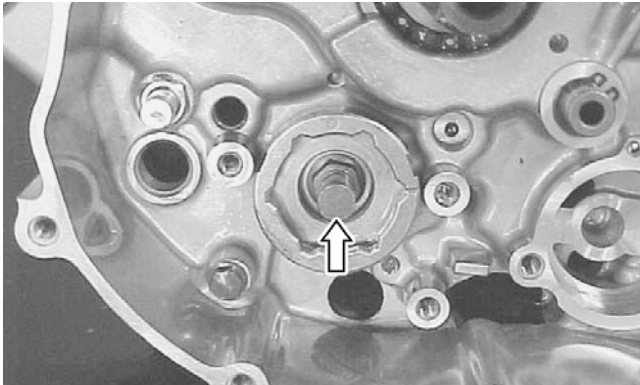

SP169

13. Holding the rotor/flywheel and using a 27 mm offset wrench, remove the crank balancer driven gear nut; then remove the washer, driven gear, and locator pin.

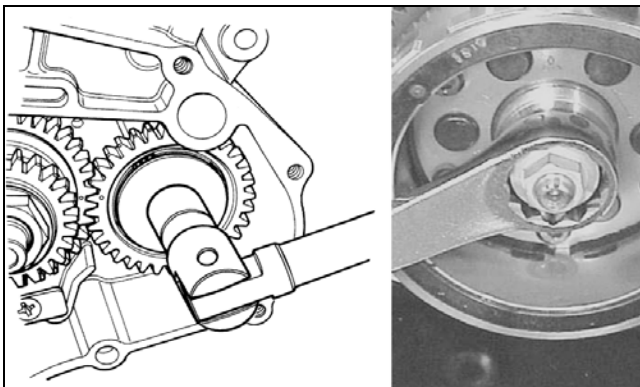

ATV2159A

14. Remove the primary drive gear nut, washer, and primary drive gear; then remove the key (1), balancer drive gear (2), and pin.

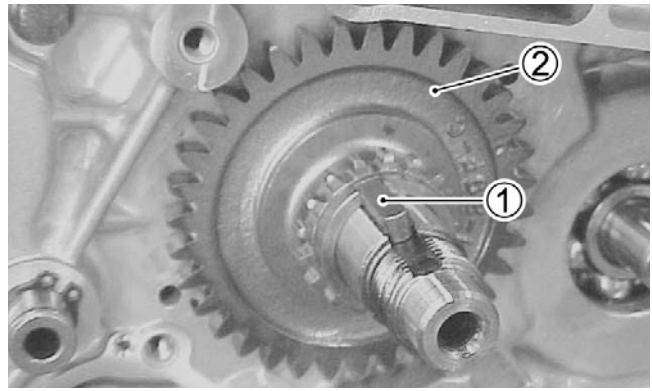

SP171

15. Holding the rotor/flywheel with a 27 mm offset wrench, remove the rotor nut; then remove the rotor/flywheel using the magneto rotor remover.

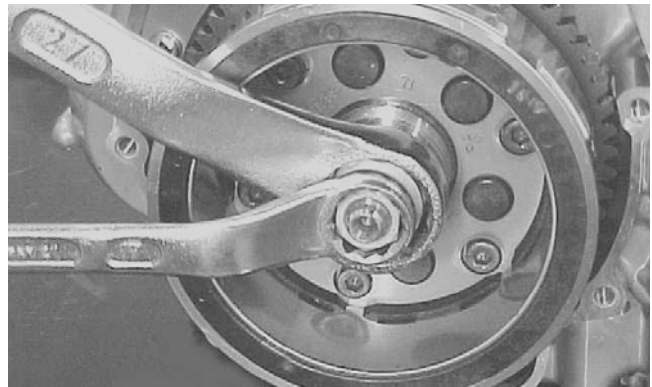

SP172

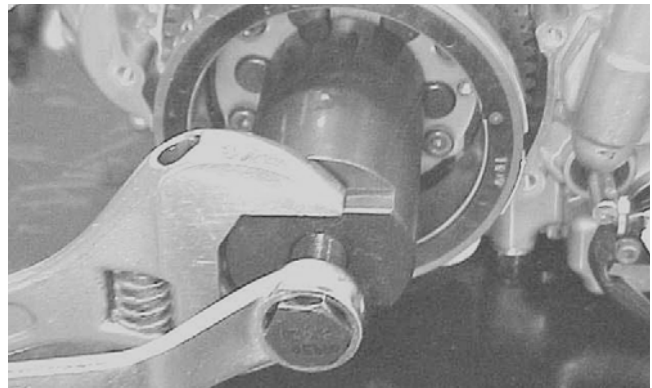

SP173

16. Remove the key (3); then remove the starter drive gear (4).

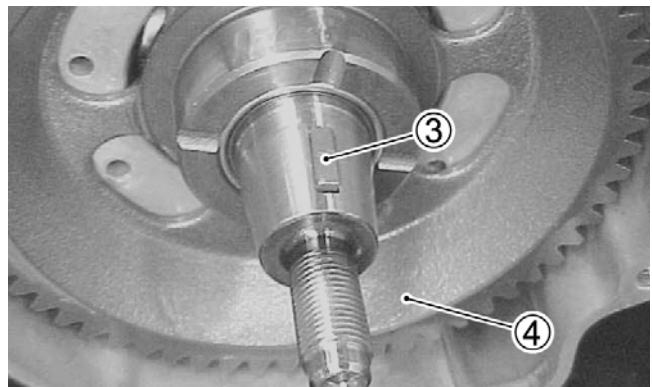

SP174

17. Remove the Allen-head cap screws securing the neutral switch housing (1); then remove the switch. Account for one O-ring (2) two switch contacts (3 and 4), and two springs behind the switch contacts.

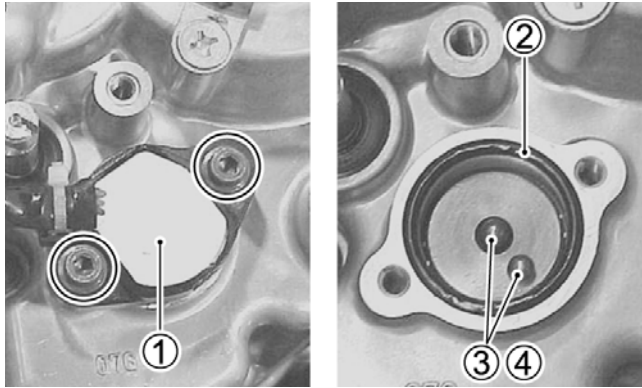

SP175A

■ **NOTE:** To aid in installing, it is recommended that the assemblies be kept together and IN ORDER.

Top-Side Components

■ **NOTE:** For efficiency, it is preferable to remove and disassemble only those components which need to be addressed and to service only those components. The technician should use discretion and sound judgment.

AT THIS POINT

To service any one specific component, only limited disassembly of components may be necessary. Note the AT THIS POINT information in each sub-section.

■ **NOTE:** The engine/transmission does not have to be removed from the frame for this procedure.

Removing Top-Side Components

- A. Valve Cover
- B. Cylinder Head
- C. Cylinder

■ **NOTE:** Remove the spark plug, timing inspection plug (1), and the alternator cover cap (2); then using a socket wrench, rotate the camshaft to top-dead-center of the compression stroke.

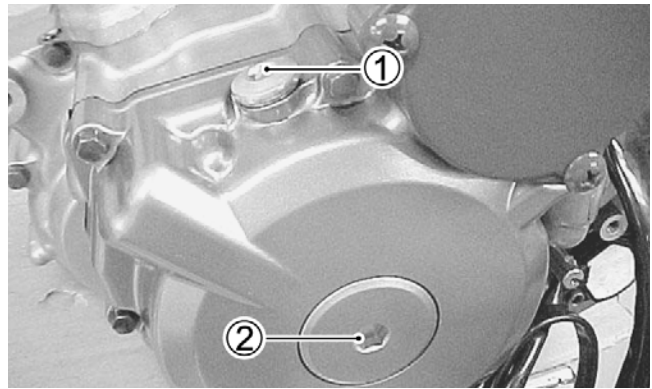

SP177

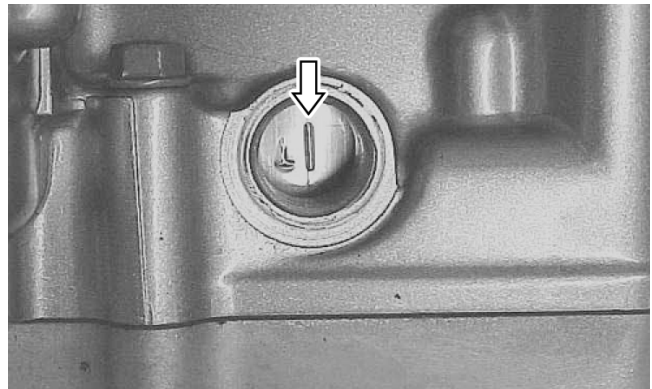

SP178

1. Remove the cap screw on the end of the tensioner; then remove the two Allen-head cap screws securing the tensioner adjuster assembly and remove the assembly. Account for a gasket and spring.



SP179



SP180

3

- Remove the valve cover cap screws in a diagonal pattern; then remove the valve cover accounting for two washers (1) and one rubber cushion (2).

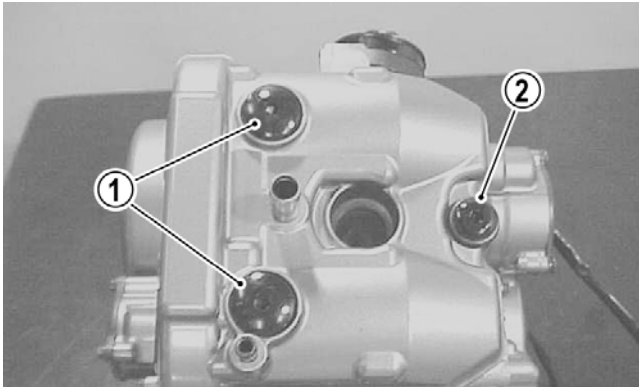

SP181A

■ **NOTE:** Before removing the camshaft journal caps, the piston must be at top-dead-center of the compression stroke.

- Remove the cam chain guide (3); then remove the camshaft journal cap screws and journal caps (4).

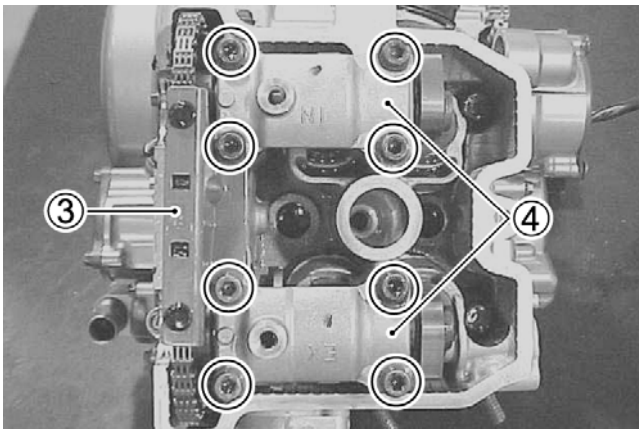

SP182

■ **NOTE:** Use caution not to drop the alignment pins or the camshaft drive chain into the crankcase.

- Remove the four alignment pins (5); then remove the intake camshaft (6) keeping tension on the chain.
- Remove the exhaust camshaft (7); then secure the chain to prevent it from dropping into the crankcase.

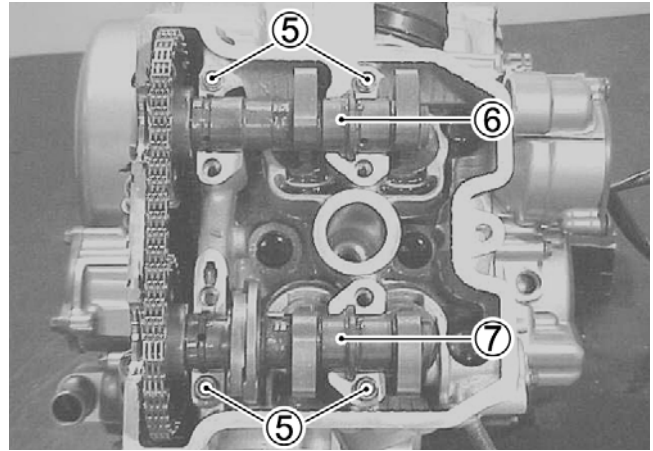

SP183

- Remove the four cylinder head cap screws in a diagonal pattern noting the locations of the 6 mm and 10 mm cap screws for installing purposes; then remove the cylinder head. Account for two alignment pins and the head gasket.

■ **NOTE:** If the cylinder head sticks, a light tap with a plastic mallet may be needed to loosen it.

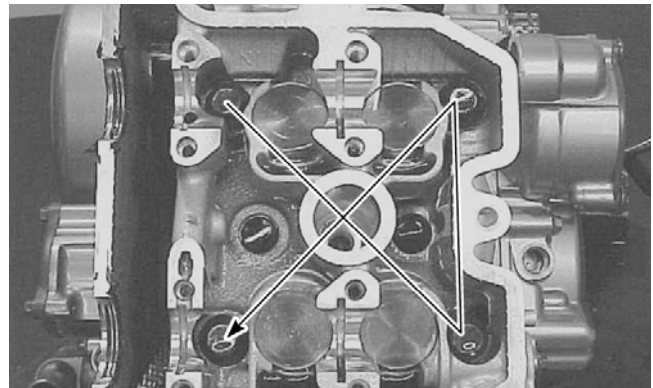

SP184

- Remove the cam chain guide (3); then remove the remaining two nuts (4) securing the cylinder to the crankcase.

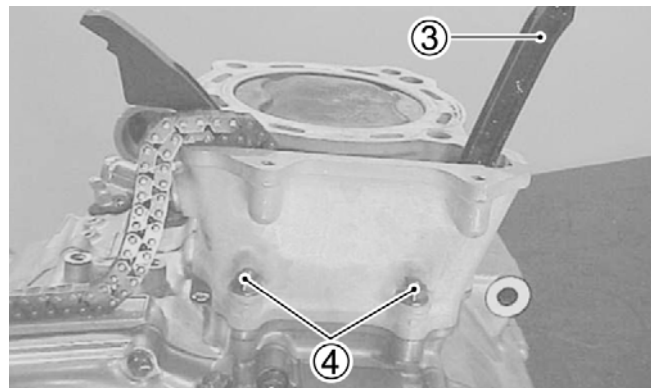

SP185

- Lift the cylinder off the crankcase taking care not to allow the piston to drop against the crankcase. Account for the gasket and two alignment pins.

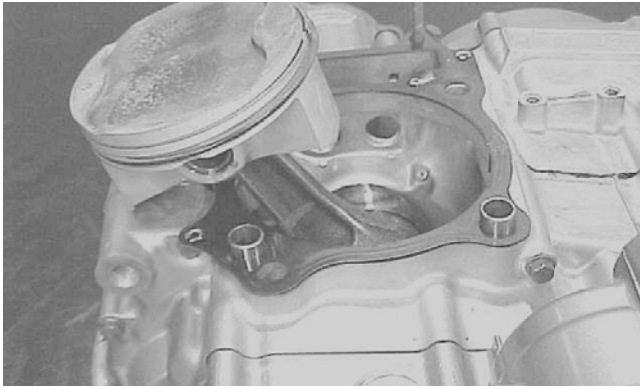

SP186

AT THIS POINT

To service cylinder, see Servicing Top-Side Components sub-section.

CAUTION

When removing the cylinder, be sure to support the piston to prevent damage to the crankcase and piston.

■ **NOTE:** Place a clean rag over the cylinder to prevent the piston-pin circlip from dropping into the crankcase.

9. Using an awl, remove one piston-pin circlip.

10. Push out the piston pin; then remove the piston. Account for the second piston-pin circlip.

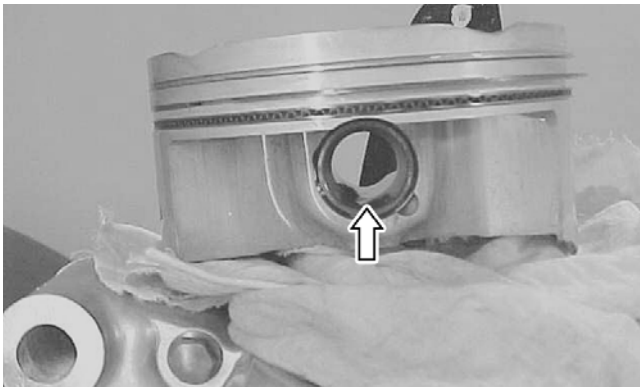

SP187

AT THIS POINT

To service center crankcase components only, proceed to Separating Crankcase Halves.

Center Crankcase Components

■ **NOTE:** This procedure cannot be done with the engine/transmission in the frame. Complete Removing procedures for Left-Side, Right-Side, and Top-Side must precede this procedure.

■ **NOTE:** For efficiency, it is preferable to remove and disassemble only those components which need to be addressed and to service only those components. The technician should use discretion and sound judgment.

Separating Crankcase Halves

3

1. Remove the cap screws from the left-side crankcase; then remove the right-side cap screws.

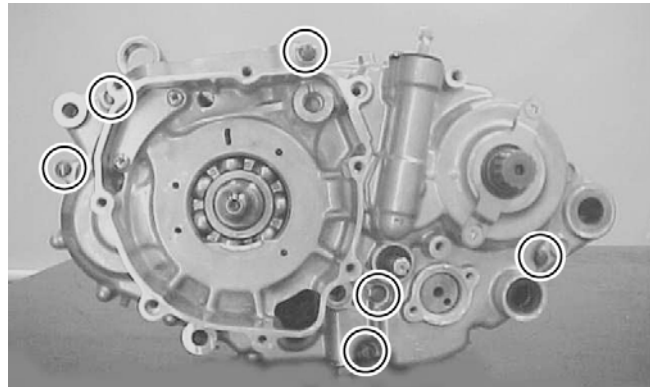

SP188

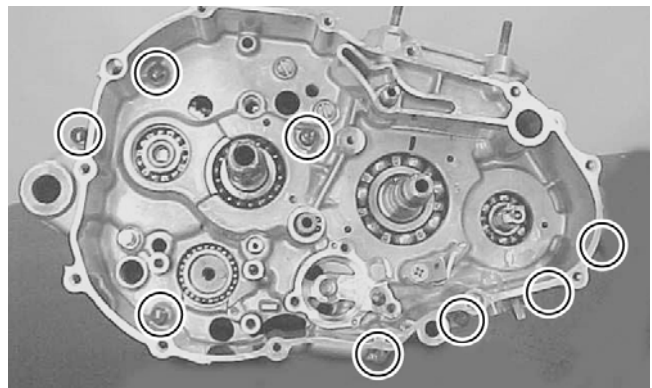

SP189

2. Install Crankcase Separator/Crankshaft Remover (p/n 0444-009) on the right-side crankcase aligning the puller screw with the crankshaft; then separate the crankcase.

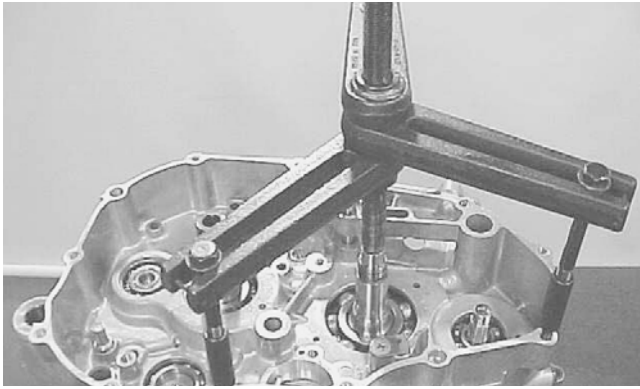

SP190

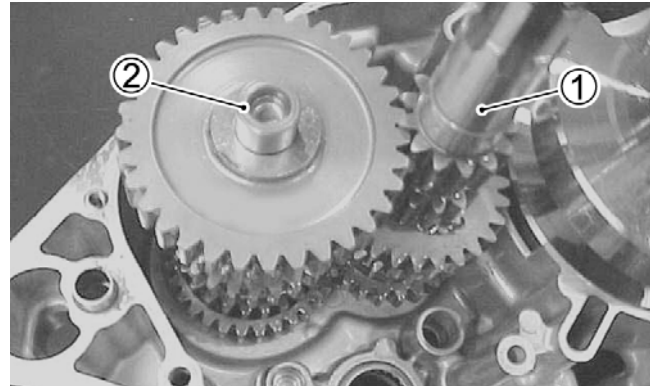

SP193

Disassembling Crankcase Half

1. Remove the alignment pin (5), shift fork shaft (6), reverse lock shaft (7), shift forks (8), and the shift cam (9).

■ **NOTE:** Note the location of each shift fork for assembling purposes.

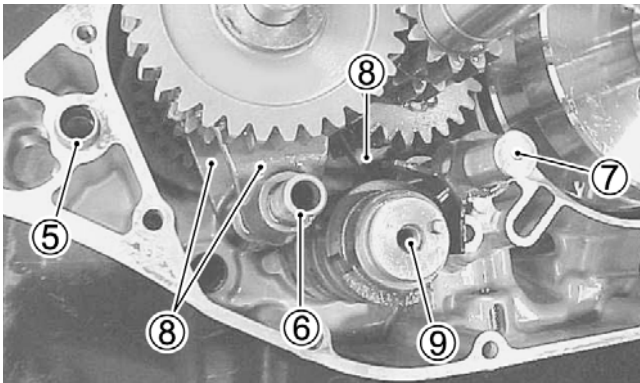

SP191

2. Remove the reverse idler gear and shaft; then remove the countershaft assembly (1) and driveshaft assembly (2).

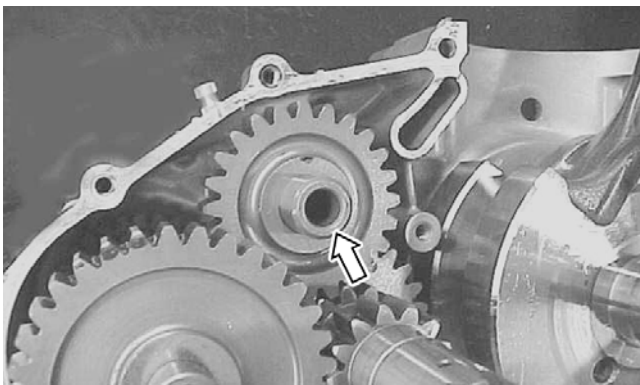

SP192

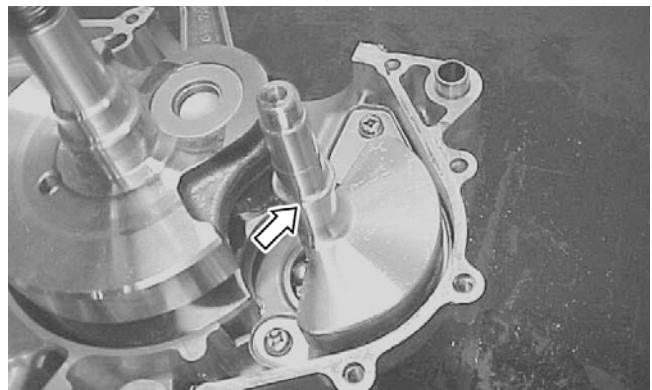

SP194

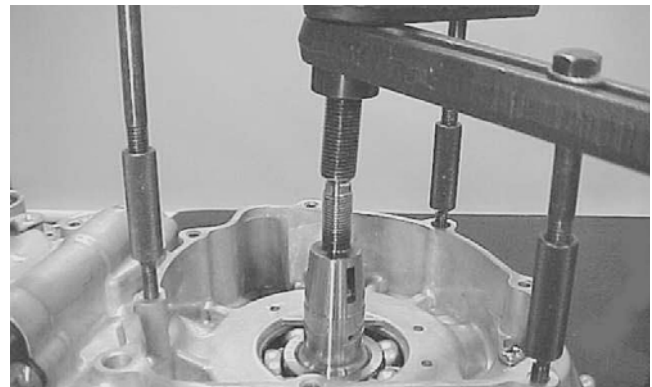

SP195

3. Remove the crank balancer shaft; then using the Crankcase Separator/Crankshaft Remover (p/n 0444-009), remove the crankshaft from the crankcase.

Table of Contents

(Servicing Components)

■ **NOTE:** Critical engine/transmission specifications are located at the beginning of this section.

Servicing Top-Side Components	3-15
Valve Assembly	3-15
Piston Assembly	3-19
Cylinder/Cylinder Head Assembly	3-21
Servicing Left-Side Components	3-23
Starter Clutch	3-23
Starter Torque Limiter	3-24
Servicing Right-Side Components	3-24
Primary Clutch Assembly	3-24
Oil Pump	3-25
Crank Balancer Driven Gear	3-25
Servicing Center Crankcase Components	3-26
Crankcase	3-26
Crankshaft Assembly	3-27
Driveshaft	3-28
Countershaft	3-32

Servicing Top-Side Components

■ **NOTE:** Whenever a part is worn excessively, cracked, or damaged in any way, replacement is necessary.

VALVE ASSEMBLY

When servicing valve assembly, inspect valve seats, valve stems, valve faces, and valve stem ends for pits, burn marks, or other signs of abnormal wear.

■ **NOTE:** Whenever a valve is out of tolerance, it must be replaced.

Cleaning/Inspecting Valve Cover

■ **NOTE:** Always note the position of each removed part. Organize the parts in relative groups (i.e. exhaust or intake) so they can be installed in their original positions.

1. Remove the intake hose; then remove the thermostat housing (1) and thermostat (2).

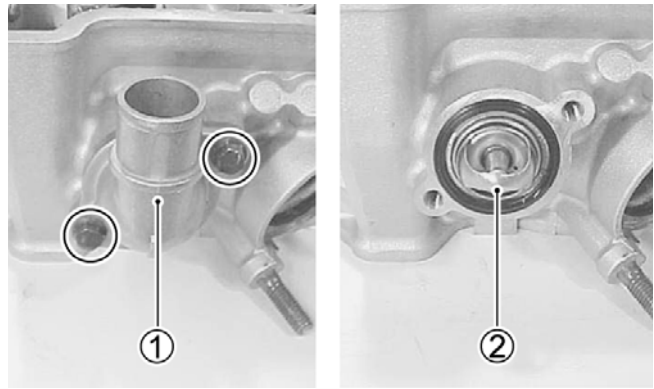

SP196A

2. Using a suitable magnet, remove the tappets (3) and the shims (4).

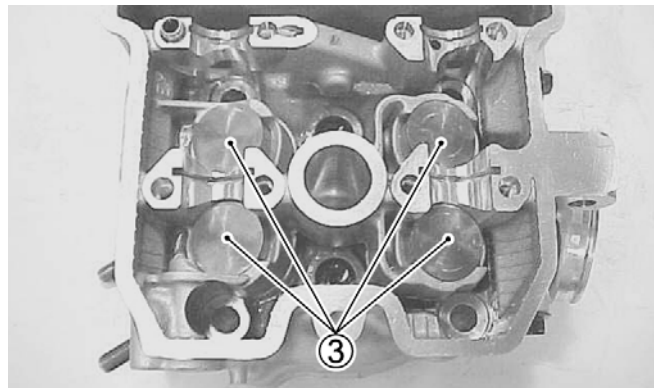

SP199

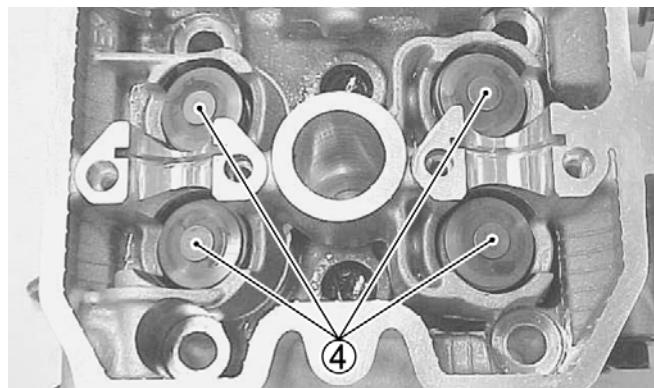

SP198

3. Using a valve spring compressor and special adapter to compress the valve springs, remove the valve cotter pins (1) from the valve stems.

■ **NOTE:** Keep valve, tappets, springs, and cotter pins together and note the location from which they came on the cylinder head.

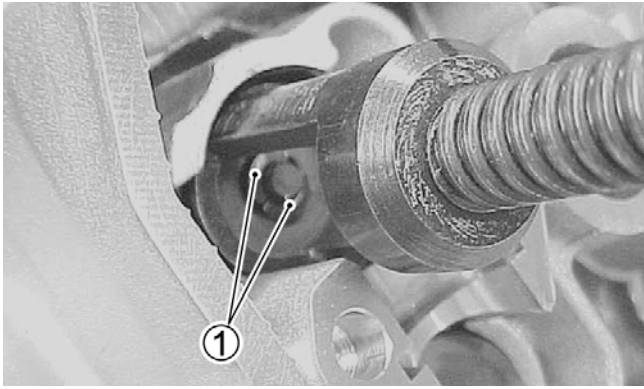

SP200

4. Remove the valve spring retainer (2) and the valve spring (3); then remove the valve (4).

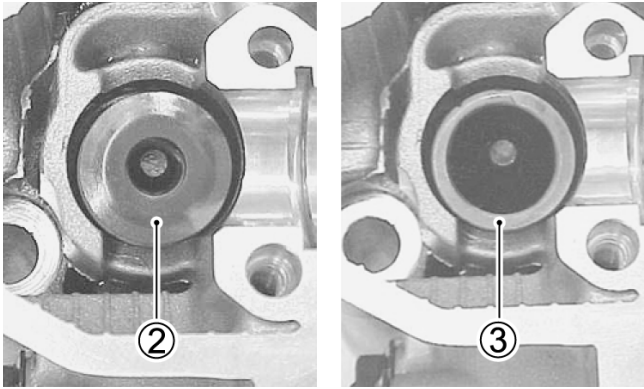

SP201A

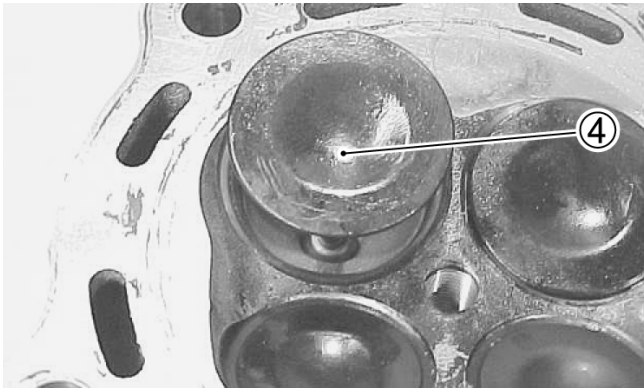

SP203

5. Remove the oil seal with a needle-nose pliers; then remove the valve spring seat.

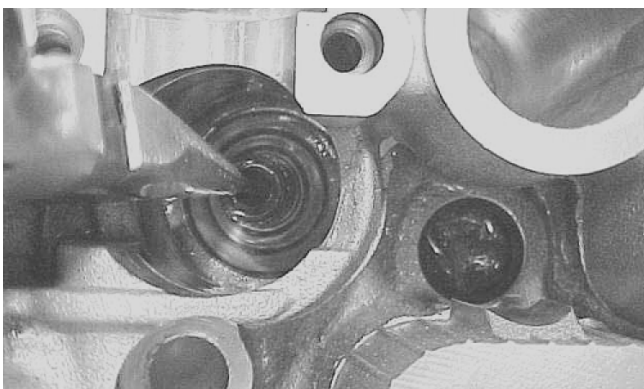

SP204

6. Check the gasket surface of the cylinder head for distortion using a straightedge and feeler gauge. Take clearance readings at several places. If any clearance reading exceeds the service limit specifications, replace the cylinder head with a new one.

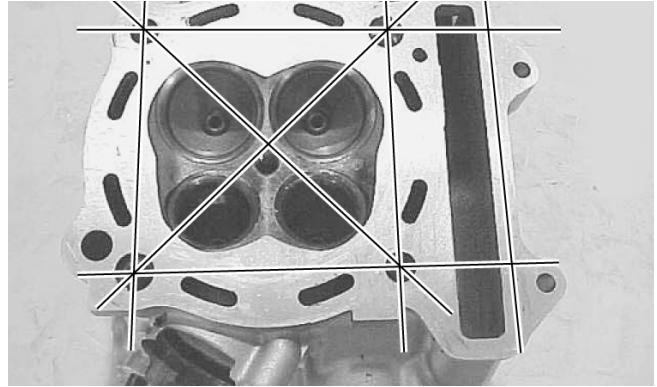

SP205

Measuring Valve Stem Runout

1. Support each valve stem end with the V Blocks (p/n 0644-022); then check the valve stem runout using a dial indicator.

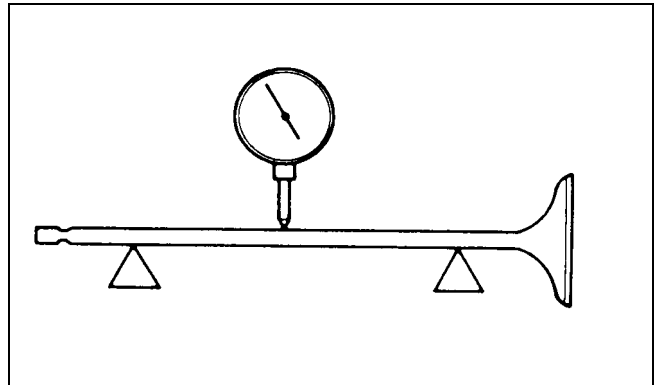

ATV-1082

2. Maximum runout must not exceed specifications.

Measuring Valve Stem Outside Diameter

1. Using a micrometer, measure the valve stem outside diameter.
2. Acceptable diameter range (intake valve) must be within specifications.
3. Acceptable diameter range (exhaust valve) must be within specifications.

Measuring Valve Face/Seat Width

1. Using a micrometer, measure the width of the valve face.

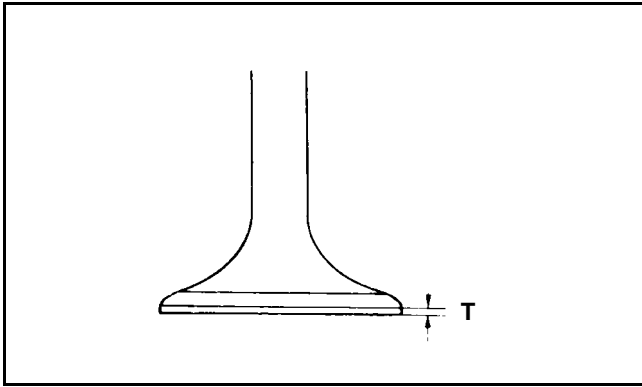

ATV-1004

2. Acceptable width range must be within specifications.

Measuring Valve Face Radial Runout

1. Mount a dial indicator on the surface plate; then place the valve stem on a set of V blocks.
2. Position the dial indicator contact point on the outside edge of the valve face; then zero the indicator.

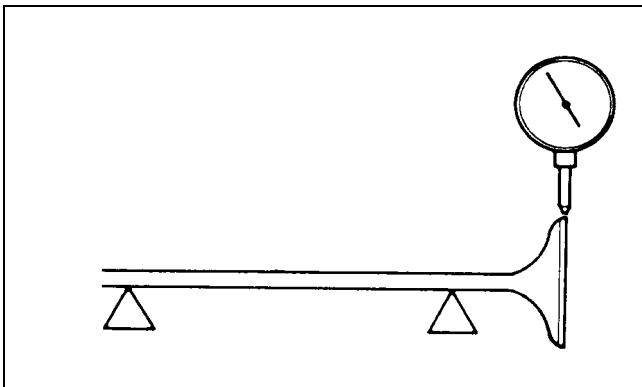

ATV1082A

3. Rotate the valve in the V blocks.
4. Maximum runout must not exceed specifications.

Measuring Valve Guide/Valve Stem Deflection (Wobble Method)

1. Mount a dial indicator and base on the surface plate; then place the cylinder head on the surface plate.
2. Install the valve into the cylinder head; then position the dial indicator contact point against the outside edge of the valve face. Zero the indicator.

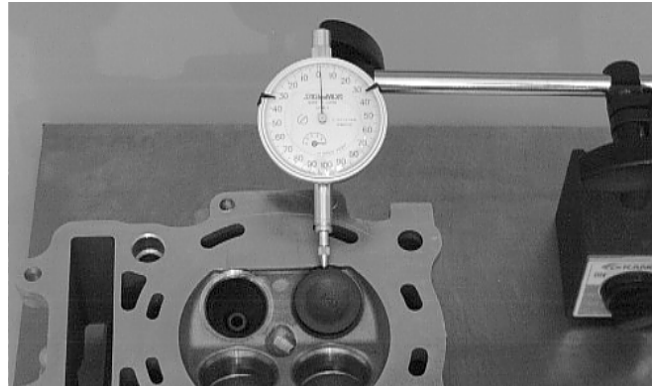

CC131D

3. Push the valve from side to side; then from top to bottom.
4. Maximum “wobble” deflection must not exceed specifications.

Measuring Valve Guide (Inside Diameter)

1. Insert a snap gauge 1/2 way down into each valve guide bore; then remove the gauge and measure it with a micrometer.
2. Acceptable inside diameter range must be within specifications.
3. If a valve guide is out of tolerance, it must be replaced.

Replacing Valve Guide

■ **NOTE:** If a valve guide is worn or damaged, it must be replaced.

1. If a valve guide needs replacing, insert a valve guide remover into the valve seat side of the valve guide. Using a hammer, gently drive the valve guide out of the cylinder head.

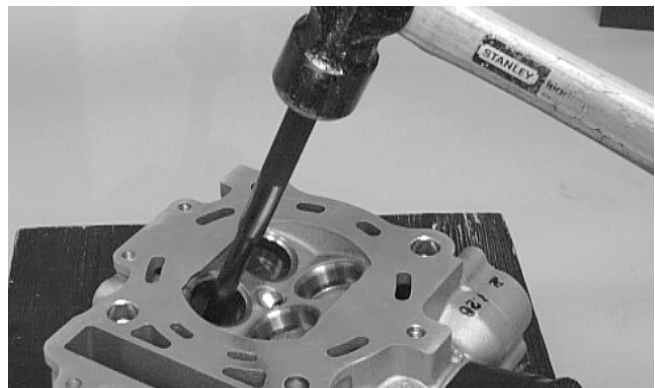

CC137D

2. Using an appropriate valve guide reamer, remove any burrs or tight areas from the valve guide journals.

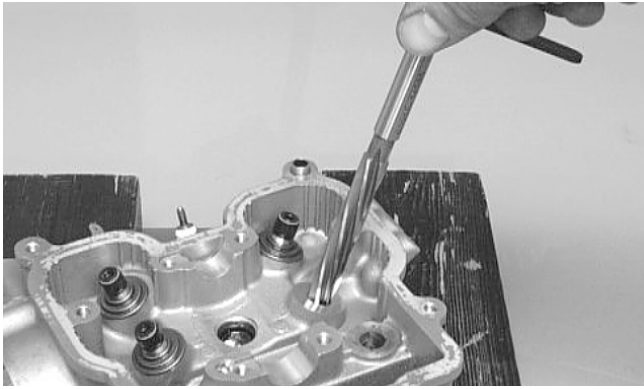

CC142D

- To install a valve guide, use a valve guide installer and gently drive a valve guide with a retaining clip into the bore from the valve spring side until the retaining clip just contacts the cylinder head.

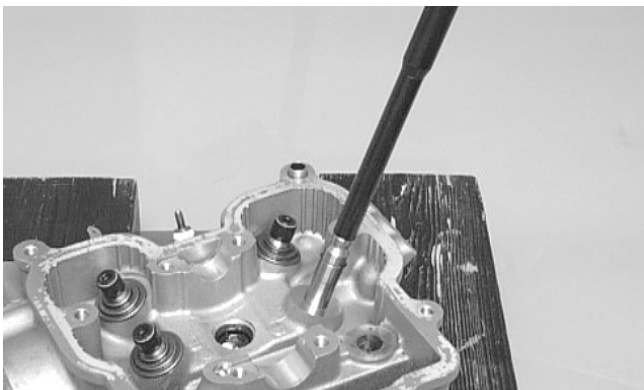

CC143D

- After installing the guide, use the standard valve guide reamer to remove all burrs and tight areas that may remain in each valve guide.



CC138D

Valve Seat/Guide Servicing Flow Chart

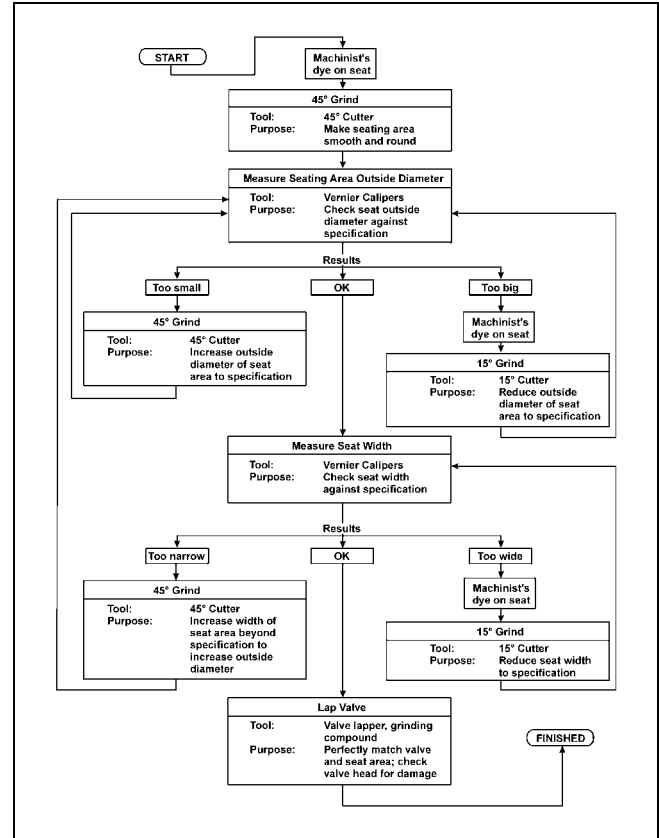

ATV-0107

Grinding Valve Seats

■ **NOTE:** If the valve seat is beyond servicing, the cylinder head must be replaced.

- Insert an exhaust valve seat pilot shaft into an exhaust valve guide. Slide an exhaust valve seat grinding tool onto the pilot shaft; then using light pressure on a driver handle and a deep socket, grind the exhaust valve seat until within specifications.

■ **NOTE:** Repeat procedure on the remaining exhaust valve.



CC139D

2. Insert an intake valve seat pilot shaft into one of the intake valve guides. Slide the intake valve seat grinding tool onto the pilot shaft; then using light pressure on a driver handle and a deep socket, grind the intake valve seat until within specifications.

■ **NOTE:** Repeat procedure on the remaining intake valve.



CC140D

Lapping Valves

■ **NOTE:** Do not grind the valves. If a valve is damaged, it must be replaced.

1. Remove all carbon from the valves.
2. Lubricate each valve stem with light oil; then apply a small amount of valve lapping compound to the entire seating face of each valve.
3. Attach the suction cup of a valve lapping tool to the head of the valve.
4. Rotate the valve until the valve and seat are evenly polished.
5. Clean all compound residue from the valve and seat.

Installing Valves

1. Apply grease to the inside surface of the valve seals; then place a lower spring seat and valve guide seal over each valve guide.

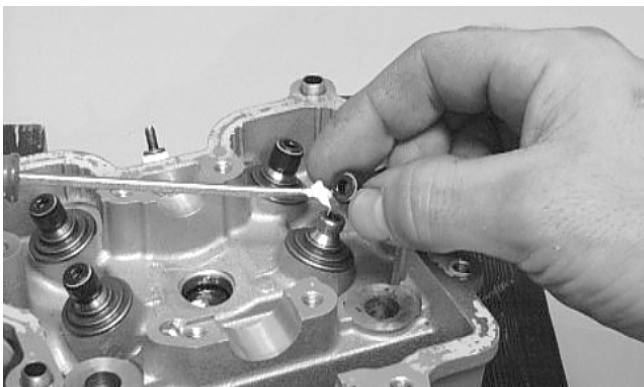

CC144D

2. Insert each valve into its original valve location.
3. Install the valve springs with the painted end of the spring facing away from the cylinder head.

■ **NOTE:** If the painted end is not visible, install the ends of the springs with the closest coils toward the head.

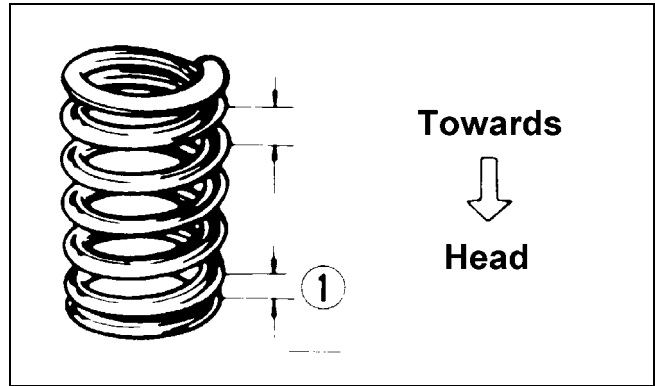

ATV-1011A

4. Place a spring retainer over the valve springs; then using the valve spring compressor, compress the valve springs and install the valve cotters.

3

PISTON ASSEMBLY

■ **NOTE:** Whenever a piston, rings, or pin are out of tolerance, they must be replaced.

Cleaning/Inspecting Piston

1. Using a non-metallic carbon removal tool, remove any carbon buildup from the dome of the piston.
2. Inspect the piston for cracks in the piston pin, dome, and skirt areas.
3. Inspect the piston for seizure marks or scuffing. Repair with #400 grit wet-or-dry sandpaper and water or honing oil.



AN135

■ **NOTE:** If scuffing or seizure marks are too deep to correct with the sandpaper, replace the piston.

4. Inspect the perimeter of each piston for signs of excessive "blowby." Excessive "blowby" indicates worn piston rings or an out-of-round cylinder.

Removing Piston Rings

1. Starting with the top ring, slide one end of the ring out of the ring-groove.



CC400D

2. Remove each ring by working it toward the dome of the piston while rotating it out of the groove.

■ **NOTE:** If the existing rings will not be replaced with new ones, note the location of each ring for proper installation. When installing new rings, install as a complete set only.

Cleaning/Inspecting Piston Rings

1. Take an old piston ring and snap it into two pieces; then grind the end of the old ring to a 45° angle and to a sharp edge.
2. Using the sharpened ring as a tool, clean carbon from the ring-grooves. Be sure to position the ring with its tapered side up.

⚠ CAUTION

Improper cleaning of the ring-grooves by the use of the wrong type of ring-groove cleaner will result in severe damage to the piston.

Measuring Piston-Ring End Gap (Installed)

1. Place each piston ring in the wear portion of the cylinder. Use the piston to position each ring squarely in the cylinder.
2. Using a feeler gauge, measure each piston-ring end gap. Acceptable ring end gap must be within specifications.

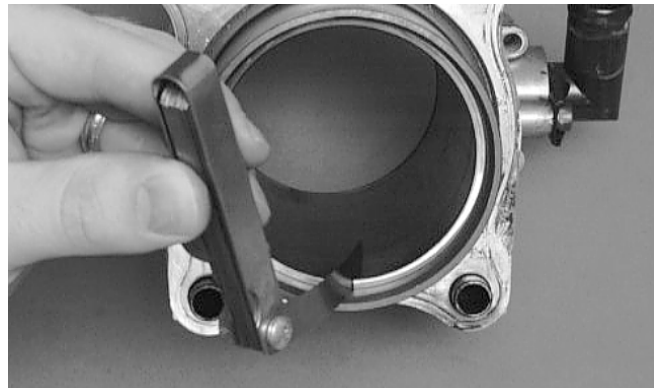

CC280D

Measuring Piston Pin (Outside Diameter) and Piston-Pin Bore

1. Measure the piston pin outside diameter at each end and in the center. If measurement is not within specifications, the piston pin must be replaced.

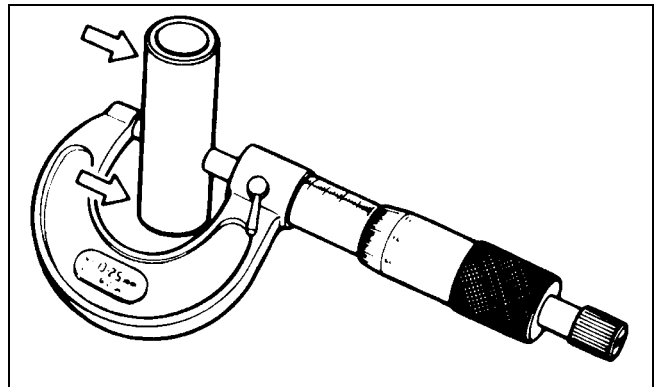

ATV-1070

2. Insert an inside dial indicator into the piston-pin bore. The diameter must not exceed specifications. Take two measurements to ensure accuracy.

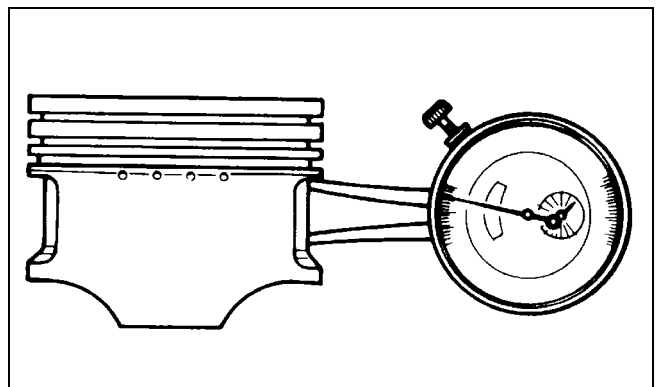

ATV-1069

Measuring Piston Skirt/ Cylinder Clearance

1. Measure the cylinder front to back in six places.

2. Measure the corresponding piston diameter at a point 15 mm (0.6 in.) above the piston skirt at a right angle to the piston-pin bore. Subtract this measurement from the measurement in step 1. The difference (clearance) must be within specifications.

CYLINDER/CYLINDER HEAD ASSEMBLY

■ **NOTE:** If the cylinder/cylinder head assembly cannot be trued, they must be replaced.

Cleaning/Inspecting Cylinder Head

⚠ CAUTION

The cylinder head studs must be removed for this procedure.

1. Using a non-metallic carbon removal tool, remove any carbon buildup from the combustion chamber being careful not to nick, scrape, or damage the combustion chamber or the sealing surface.
2. Inspect the spark plug hole for any damaged threads. Repair damaged threads using a “heli-coil” insert.
3. Place the cylinder head on the surface plate covered with #400 grit wet-or-dry sandpaper. Using light pressure, move the cylinder head in a figure eight motion. Inspect the sealing surface for any indication of high spots. A high spot can be noted by a bright metallic finish. Correct any high spots before assembly by continuing to move the cylinder head in a figure eight motion until a uniform bright metallic finish is attained.

⚠ CAUTION

Water or parts-cleaning solvent must be used in conjunction with the wet-or-dry sandpaper or damage to the sealing surface may result.

Measuring Cylinder Head Distortion

1. Remove any carbon buildup in the combustion chamber.
2. Lay a straightedge across the cylinder head; then using a feeler gauge, check the distortion factor between the head and the straightedge.
3. Maximum distortion must not exceed specifications.

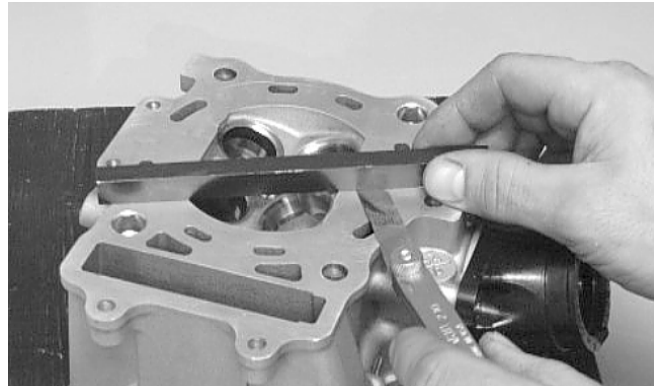

CC141D

Cleaning/Inspecting Cylinder

1. Wash the cylinder in parts-cleaning solvent.
2. Inspect the cylinder for pitting, scoring, scuffing, warpage, and corrosion.
3. Place the cylinder on the surface plate covered with #400 grit wet-or-dry sandpaper. Using light pressure, move the cylinder in a figure eight motion. Inspect the sealing surface for any indication of high spots. A high spot can be noted by a bright metallic finish. Correct any high spots before assembly by continuing to move the cylinder in a figure eight motion until a uniform bright metallic finish is attained.

3

⚠ CAUTION

Water or parts-cleaning solvent must be used in conjunction with the wet-or-dry sandpaper or damage to the sealing surface may result.

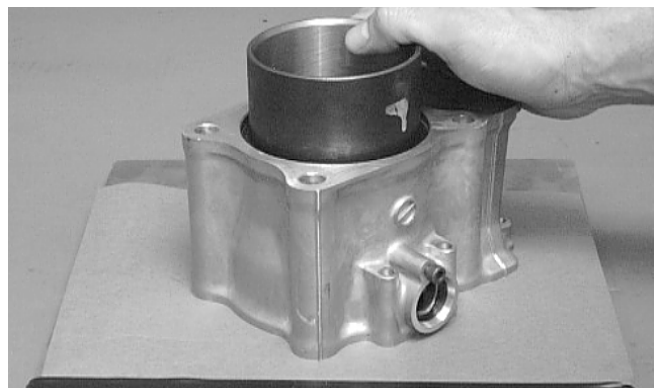

CC129D

Inspecting Cam Chain Guide

1. Inspect cam chain guide for cuts, tears, breaks, or chips.
2. If the chain guide is damaged, it must be replaced.

Inspecting Cylinder

1. Using a slide gauge and a dial indicator or a snap gauge, measure the cylinder bore diameter in three locations from top to bottom and again from top to bottom at 90° from the first measurements for a total of six measurements. The trueness (out-of-roundness) is the difference between the highest and lowest reading. Maximum trueness (out-of-roundness) must not exceed specifications.

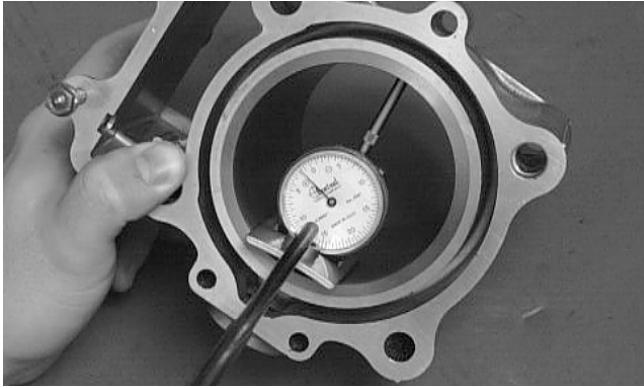

CC127D

2. Wash the cylinder in parts-cleaning solvent.
3. Inspect the cylinder for pitting, scoring, scuffing, and corrosion. If marks are found, the cylinder must be replaced.

■ **NOTE:** Nicksil-plated cylinder cannot be honed.

Measuring Camshaft Runout

■ **NOTE:** If the camshaft is out of tolerance, it must be replaced.

1. Place the camshaft on a set of V blocks; then position the dial indicator contact point against the shaft and zero the indicator.

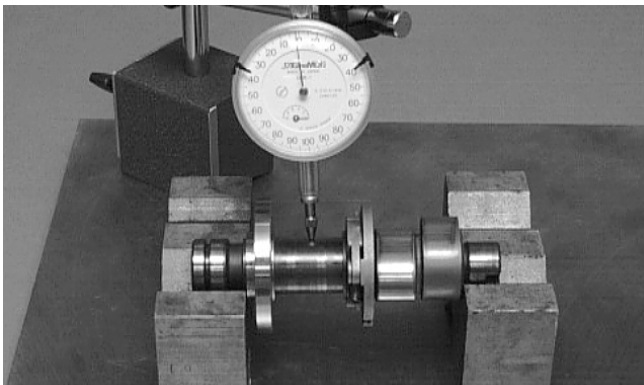

CC283D

2. Rotate the camshaft and note runout; maximum tolerance must not exceed specifications.

Measuring Camshaft Lobe Height

1. Using a calipers, measure each cam lobe height.

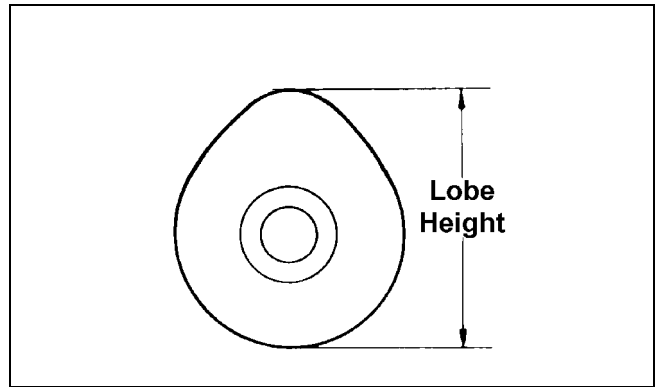

ATV1013A

2. The lobe heights must not exceed minimum specifications.

Inspecting Camshaft Bearing Journal

1. Inspect the bearing journal for scoring, seizure marks, or pitting.
2. If excessive scoring, seizure marks, or pitting is found, the cylinder head assembly must be replaced.

Measuring Camshaft to Cylinder Head Clearance

1. Place a strip of plastigauge in each of the camshaft lands in the cylinder head.
2. Install the camshaft journal caps on the cylinder head and secure with the cap screws. Tighten to specifications.

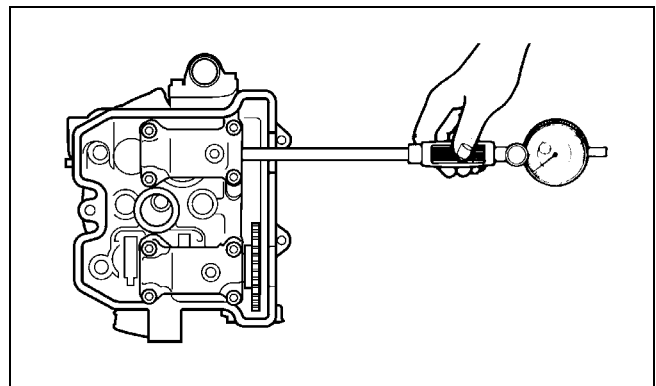

ATV2160

■ **NOTE:** Do not rotate the camshaft when measuring clearance.

3. Remove the cap screws securing the journal caps to the cylinder head; then remove the journal caps and camshafts.
4. Match the width of the plastigauge with the chart found on the plastigauge packaging to determine camshaft to cylinder head journal clearance.

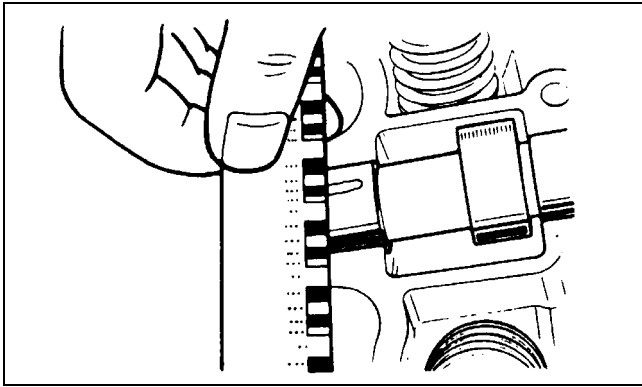

ATV2161

5. If clearance is excessive, measure the journals of the camshaft.

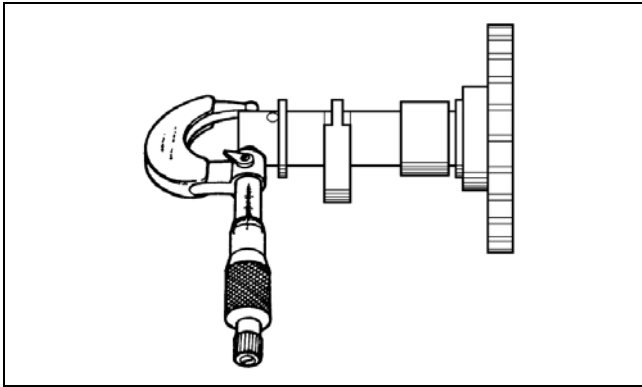

ATV2162

■ **NOTE:** If the journals are worn, replace the camshaft; then measure the clearance again. If it is still out of tolerance, replace the cylinder head.

Inspecting Camshaft/Automatic Decompression Assembly

1. Move the automatic decompression weights by hand to check for freedom of movement. If the weights do not move smoothly or bind, the camshaft must be replaced.

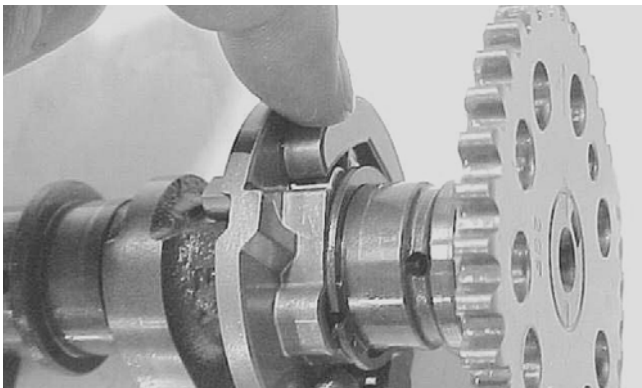

SP206

2. If damaged, the camshaft must be replaced.

Servicing Left-Side Components

STARTER CLUTCH

To replace the starter clutch, use the following procedure.

1. Hold the rotor/flywheel using a 27 mm offset wrench; then remove the six Allen-head cap screws securing the starter clutch housing.

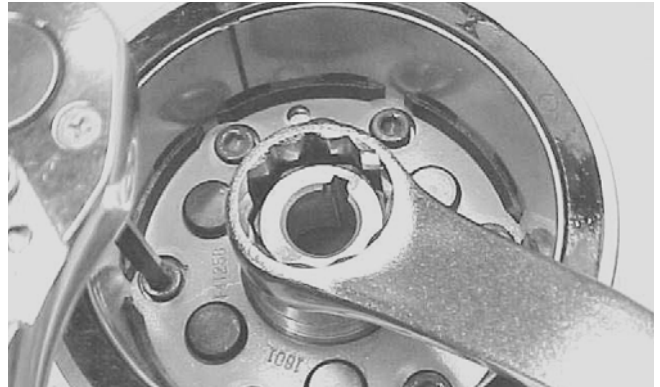

SP207

2. Install the new starter clutch making sure the flange side (A) is directed toward the rotor/flywheel; then install the six Allen-head cap screws and tighten securely. Apply engine oil to the starter clutch assembly.

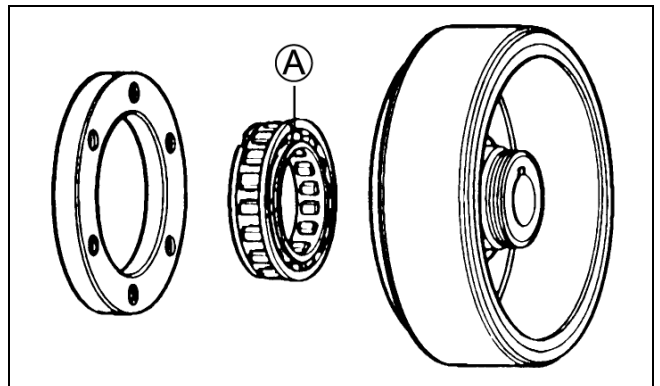

ATV2163



SP208

3. Install the starter driven gear (1) into the starter clutch; then check that the rotor (2) turns in the direction of the arrow (3) while holding the driven gear. Check in several positions and make certain the rotor never turns opposite the arrow.

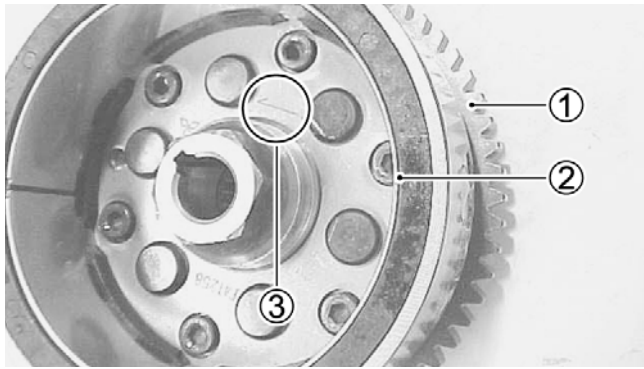

SP209

STARTER TORQUE LIMITER

■ **NOTE:** Do not attempt to disassemble the starter torque limiter. It is not serviceable.

To check the slip-torque of the starter torque limiter, use a holding fixture, special socket, and a torque wrench as shown. If the slip-torque is not within 3.0-5.5 kg-m (22-40 ft-lb), replace the starter torque limiter.

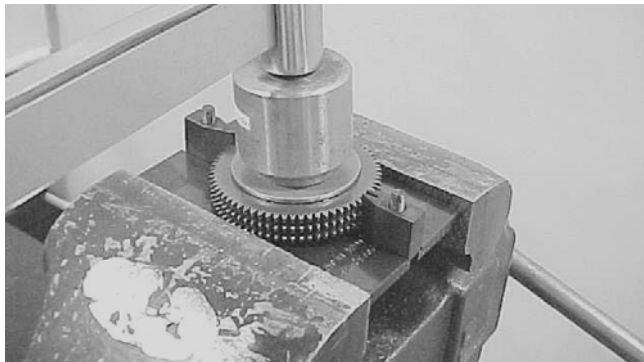

SP210

Servicing Right-Side Components

■ **NOTE:** Whenever a part is worn excessively, cracked, damaged in any way, or out of tolerance, replacement is necessary.

PRIMARY CLUTCH ASSEMBLY (Inspecting/Measuring)

■ **NOTE:** Prior to inspecting and measuring components, it is recommended that all components be removed from the primary driven gear assembly and be cleaned.

■ **NOTE:** Keep all clutch components in order and set aside for assembly after the primary driven gear is installed on the driveshaft.

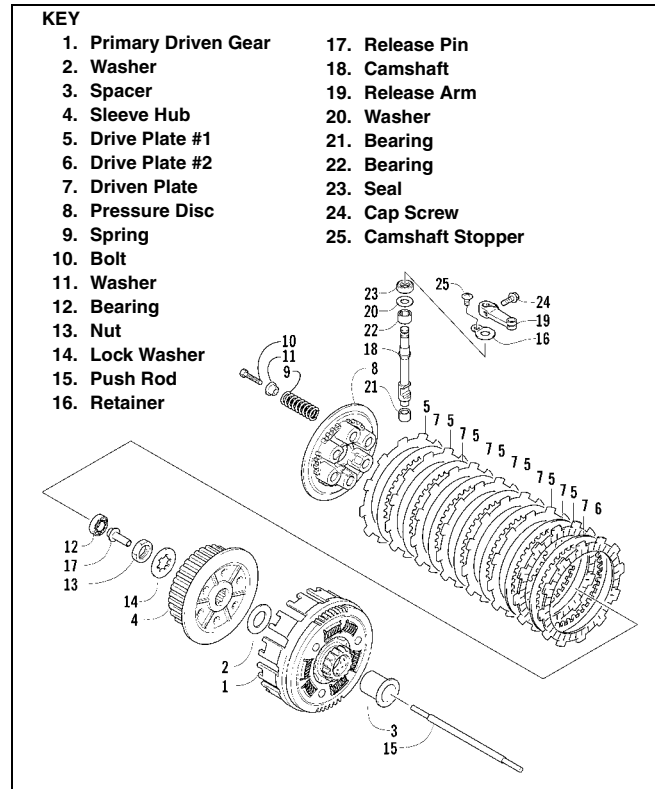

0739-225

Inspecting/Measuring Clutch Driven Plate Warpage

1. Inspect each driven plate for warpage and burn marks.
2. In turn place each driven plate on the surface plate; then using a feeler gauge, measure warpage in several locations.

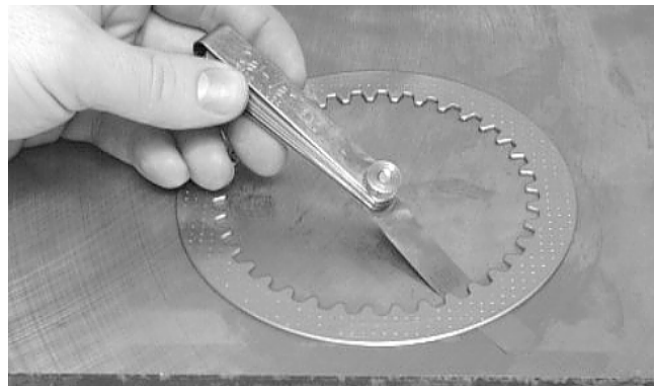

CC245D

3. Maximum driven plate warpage must not exceed specifications.

Measuring Clutch Drive Plate (Fiber) Thickness

1. Using a calipers, in turn measure the thickness of each drive plate in several locations.

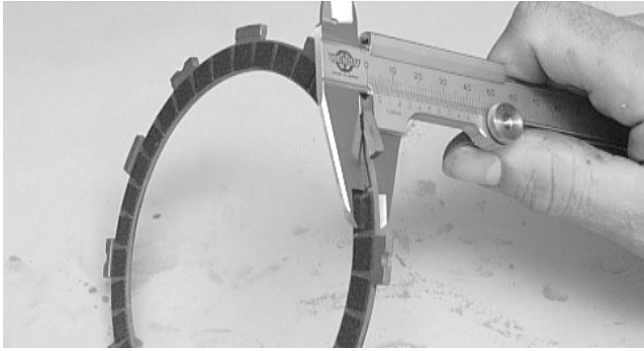

CC243D

2. Drive plate thickness must be within minimum specifications.
3. If the fiber plate tabs are damaged, the plate must be replaced.
4. Inspect the clutch sleeve hub for grooves or notches. If grooves or notches are present, replace the hub.

OIL PUMP (Inspecting/Serviceing)

1. Remove the outer rotor (1), inner rotor (2), and the pin (4); then inspect the outer and inner rotors for nicks, scratches, or other damage. Replace any damaged parts.

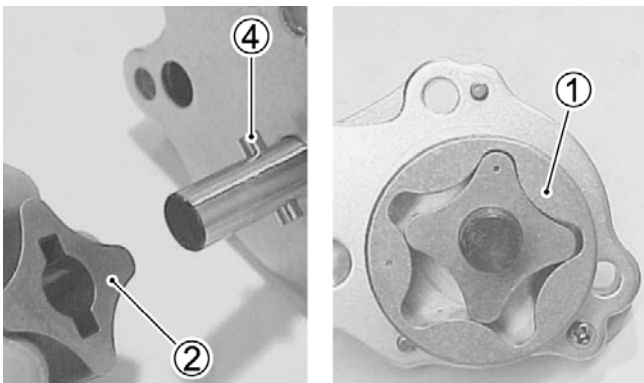

SP211A

■ **NOTE:** Do not attempt to disassemble the oil pump housing assembly. It is serviceable only as a complete unit.

2. Apply engine oil to the mating surfaces of the inner and outer rotors; then align the groove (5) of the inner rotor with the pin (4) of the shaft and install the inner rotor.
3. Install the outer rotor.

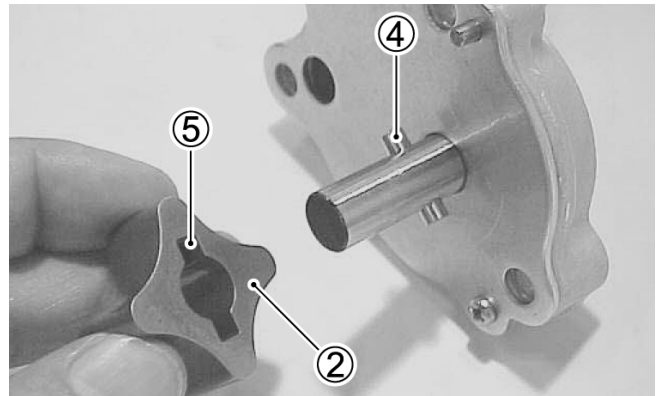

SP213

CRANK BALANCER DRIVEN GEAR

1. Remove the nut and large flat washer from the crank balancer shaft; then remove the driven gear.

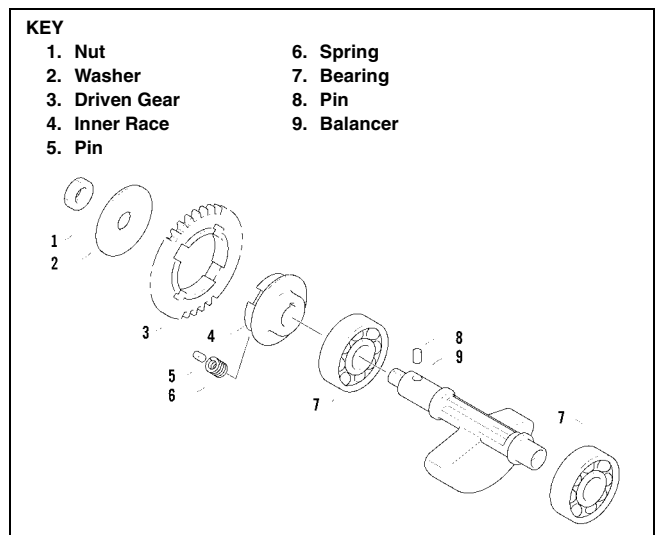

0739-185

2. Separate the driven gear from the driven gear inner race and account for four springs and two pins.
3. Measure the free length of the springs. If any spring free length is less than 10.3 mm (0.41 in.), replace all four springs.

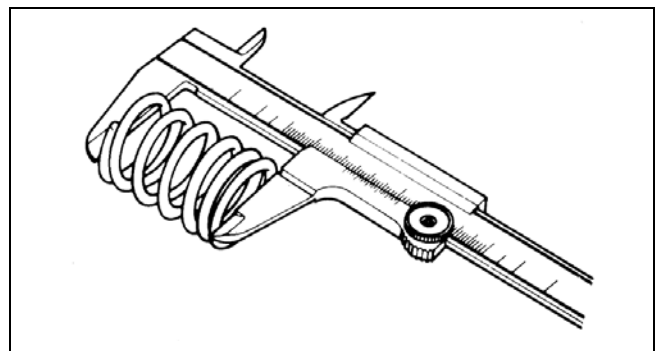

ATV2166

4. Assemble the balancer driven gear noting the position of the two pins (A) and alignment of the two punch marks.

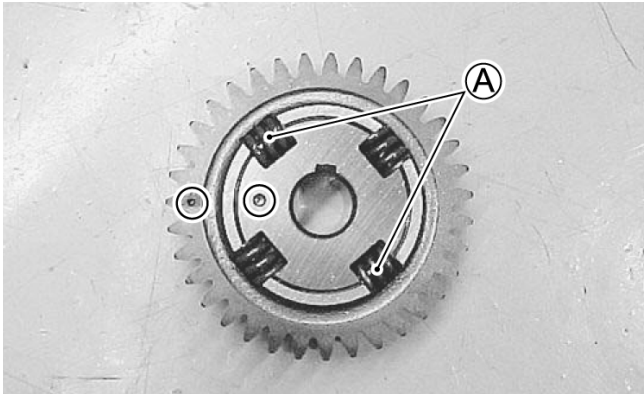

SP214

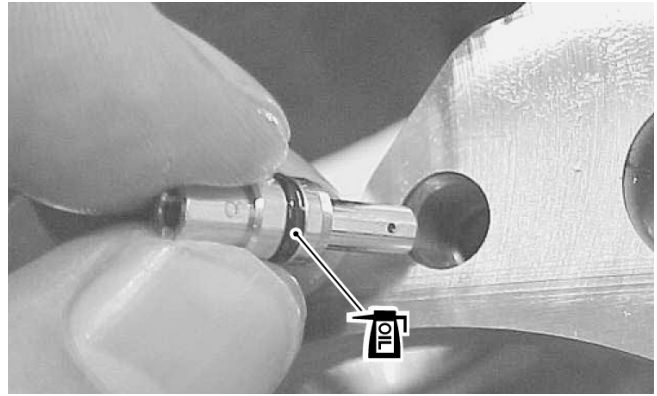

SP216

3. Install the oil pump idler gear shaft (1); then apply red Loctite #271 to the shift arm stopper (2) and tighten to specification.

Servicing Center Crankcase Components

■ **NOTE:** Whenever a part is worn excessively, cracked, damaged in any way, or out of tolerance, replacement is necessary.

CRANKCASE (Cleaning and Inspecting)

1. Remove the oil sump filter and clean using compressed air; then align the oil passage holes and install the sump filter.

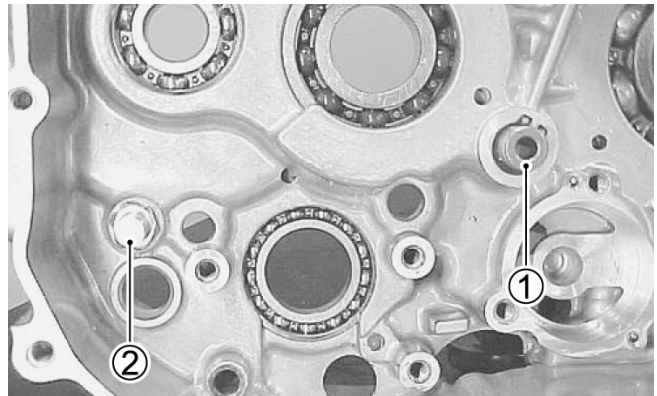

SP217

4. Wash the bearings with solvent and lubricate them with clean engine oil; then rotate the bearings by hand. If the bearings do not rotate smoothly and quietly, they must be replaced. Check for excessive radial and lateral play.

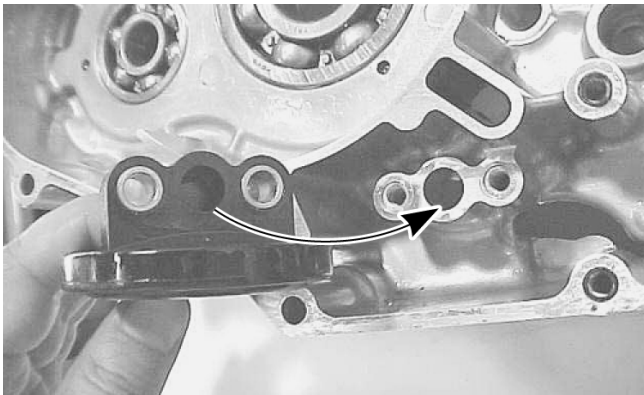

SP215

2. Remove the oil jet, install a new O-ring, apply engine oil, and install.

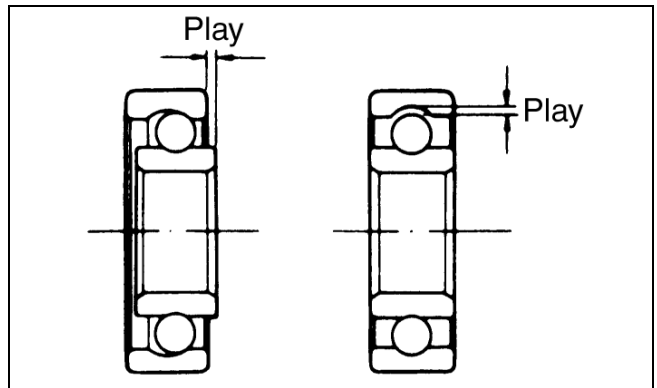

ATV2167

5. To replace a bearing, remove the bearing retaining screws; then use the bearing remover to pull the bearing from the crankcase.

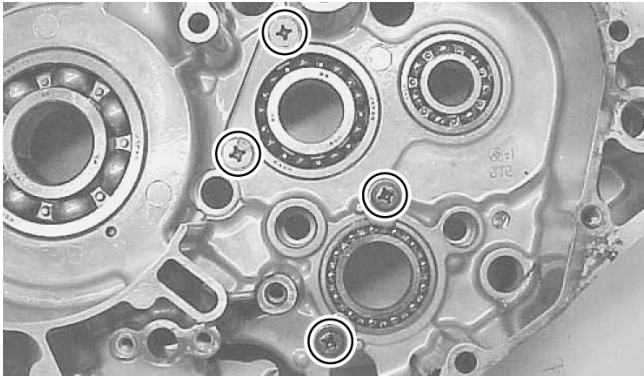

SP218

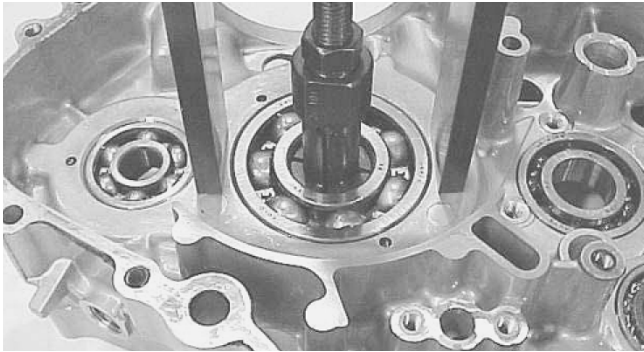

SP219

6. Install the new bearing using the bearing installer; then apply a small amount of red Loctite #271 to the bearing retainer screws and tighten securely.

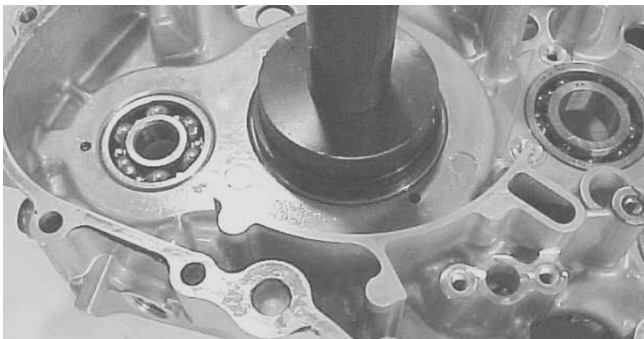

SP220

7. Inspect all the oil seals for wear, nicks, or lip damage. If any damage is found, replace the seal.
8. Thoroughly clean all crankcase mating surfaces prior to assembly.

CRANKSHAFT ASSEMBLY

Measuring Connecting Rod (Small End Inside Diameter)

1. Insert a snap gauge into the upper connecting rod small end bore; then remove the gauge and measure it with micrometer.

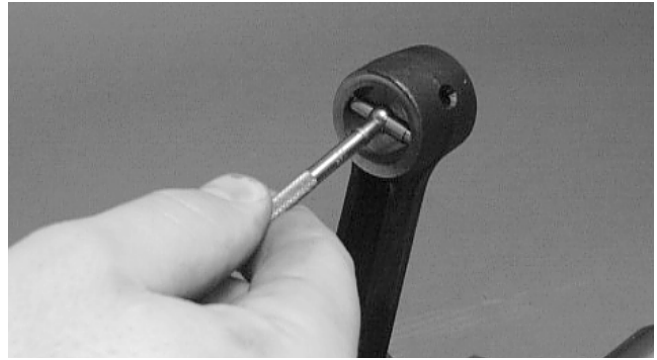

CC290D

2. Maximum diameter must not exceed specifications.

Measuring Connecting Rod (Small End Deflection)

1. Place the crankshaft on a set of V-blocks and mount a dial indicator and base on the surface plate. Position the indicator contact point against the center of the connecting rod small end journal.
2. Zero the indicator and push the small end of the connecting rod away from the dial indicator.
3. Maximum deflection must not exceed specifications.

3

Measuring Connecting Rod (Big End Side-to-Side)

1. Push the lower end of the connecting rod to one side of the crankshaft journal.
2. Using a feeler gauge, measure the gap between the connecting rod and crankshaft journal.



CC289D

3. Acceptable gap range must be within specifications.

Measuring Connecting Rod (Big End Width)

1. Using a calipers, measure the width of the connecting rod at the big-end bearing.
2. Acceptable width range must be within specifications.

Measuring Crankshaft (Runout)

1. Place the crankshaft on a set of V blocks.
2. Mount a dial indicator and base on the surface plate. Position the indicator contact at point 1 of the crankshaft.

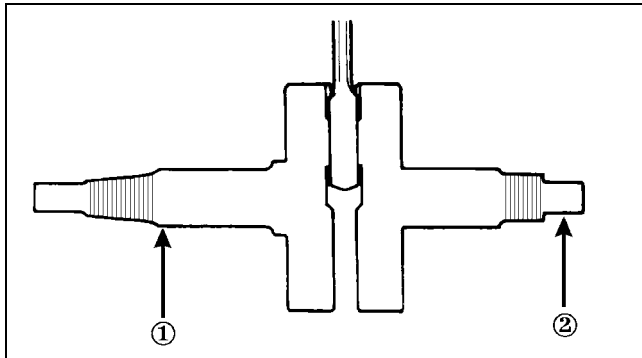

ATV-1074

3. Zero the indicator and rotate the crankshaft slowly.

⚠ CAUTION

Care should be taken to support the connecting rod when rotating the crankshaft.

4. Maximum runout must not exceed specifications.

■ **NOTE:** Proceed to check runout on the other end of the crankshaft by positioning the indicator contact at point 2 and following steps 2-4.

Measuring Crankshaft (Web-to-Web)

1. Using a calipers, measure the distance from the outside edge of one web to the outside edge of the other web.

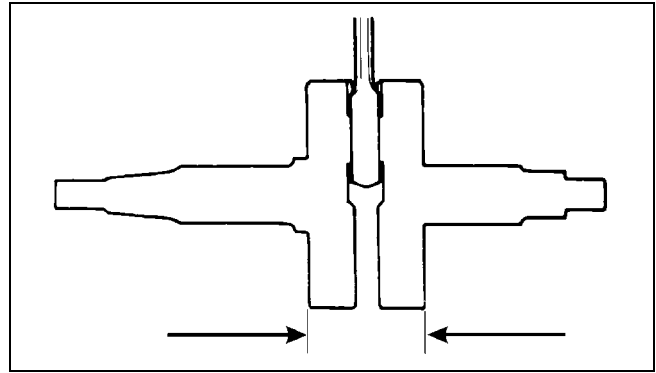

ATV-1017

2. Acceptable width range must be within specifications.

DRIVESHAFT

Disassembling

1. In order, remove the washer, 1st driven gear, and bushing from the driveshaft.
2. Remove the 1st driven washer (right side); then remove the reverse dog from the driveshaft.



CC223D

■ **NOTE:** Note the orientation of the four small dogs and the 1st driven gear for assembling purposes.

3. Remove the reverse circlip; then remove the reverse washer (left side) from the splined shaft.
4. Remove the reverse driven gear from the driveshaft.
5. Remove the reverse driven bushing; then remove the 5th driven gear from the driveshaft.
6. Remove the 3rd driven gear, bushing, and washer from the driveshaft.
7. Remove the 4th driven circlip and gear from the driveshaft.
8. In order, remove the 2nd driven circlip, washer, gear, and bushing from the driveshaft.

KEY

- | | |
|--------------------------|--|
| 1. Countershaft | |
| 2. Gear, 2nd Drive | |
| 3. Gear, 3rd Drive | |
| 4. Gear, 4th Drive | |
| 5. Gear, 5th Drive | |
| 6. Washer | |
| 7. Washer | |
| 8. Washer | |
| 9. Bearing | |
| 10. Circlip | |
| 11. Bearing | |
| 12. Driveshaft | |
| 13. Gear, 1st Driven | |
| 14. Gear, 2nd Driven | |
| 15. Gear, 3rd Driven | |
| 16. Gear, 4th Driven | |
| 17. Gear, 5th Driven | |
| 18. Gear, Reverse Driven | |
| 19. Reverse Dog | |
| 20. Bushing | |
| 21. Washer | |
| 22. Bushing | |
| 23. Bearing | |
| 24. Washer | |
| 25. Washer | |
| 26. Bearing | |
| 27. Oil Seal | |
| 28. Bushing | |
| 29. Bushing | |
| 30. Engine Sprocket | |
| 31. Chain Assy | |
| 32. Joint Set | |
| 33. Retainer | |
| 34. Screw | |
| 35. Retainer | |
| 36. Bolt | |
| 37. Reverse Idle Shaft | |
| 38. Reverse Idle Gear | |
| 39. Bushing | |
| 40. Washer | |
| 41. Washer | |
| 42. Wave Washer | |
| 43. Circlip | |
| 44. Bolt | |
| 45. Plate | |

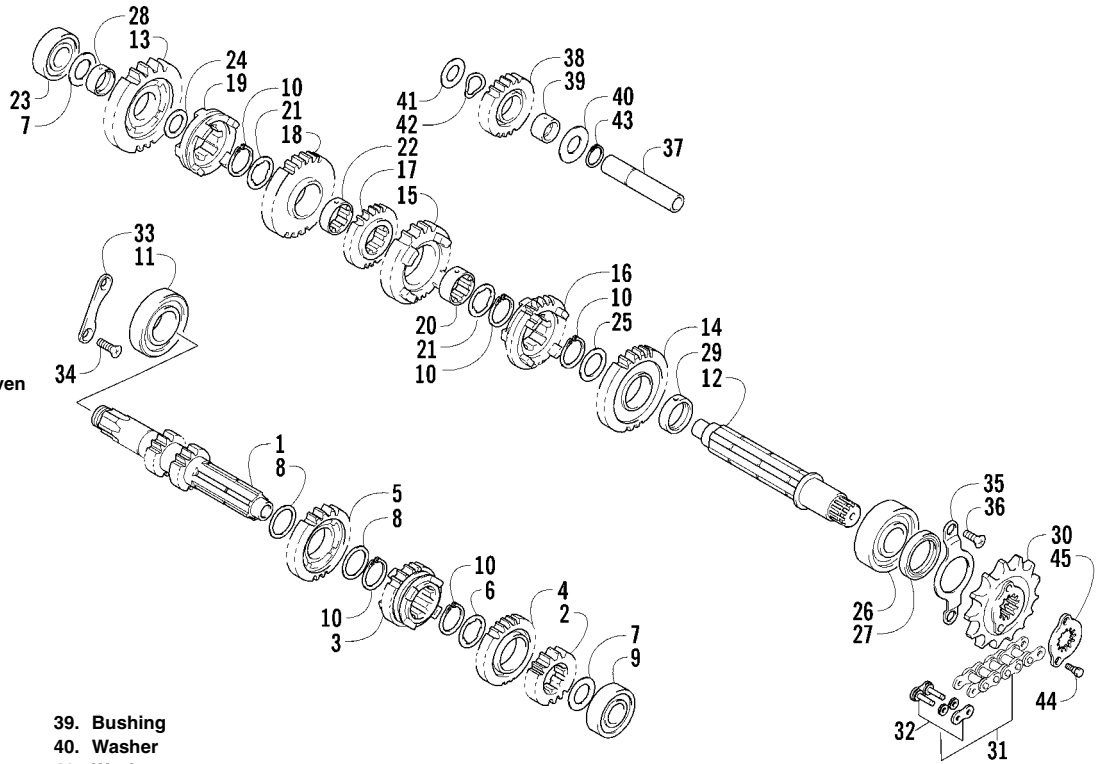

0739-226

Measuring Shift Fork/Gear

Measure the shift fork clearance in the groove of the mating gear using a feeler gauge. If the clearance exceeds specifications, proceed as follows.

- Using a calipers, measure the shift fork groove width. If it is not within specifications, the gear must be replaced.

- Using a calipers, measure the shift fork thickness. If it is not within specifications, the shift fork must be replaced.

■ **NOTE:** After a circlip has been removed from a shaft, it should be discarded and replaced with a new one.

■ **NOTE:** When assembling the transmission shafts, attention must be given to the position of the washers and circlips. The cross-sectional view shows the correct position of the gears, washers, and circlips.

Assembling

KEY

- 1. Countershaft
- 2. Gear, 2nd Drive
- 3. Gear, 3rd Drive
- 4. Gear, 4th Drive
- 5. Gear, 5th Drive
- 6. Washer
- 7. Washer
- 8. Washer
- 9. Bearing
- 10. Circlip
- 11. Bearing
- 12. Driveshaft
- 13. Gear, 1st Drive
- 14. Gear, 2nd Driven
- 15. Gear, 3rd Drive
- 16. Gear, 4th Drive
- 17. Gear, 5th Drive
- 18. Gear, Reverse Driven
- 19. Reverse Dog
- 20. Bushing
- 21. Washer
- 22. Bushing
- 23. Bearing
- 24. Washer
- 25. Washer
- 26. Bearing
- 27. Oil Seal
- 28. Bushing
- 29. Bushing
- 30. Engine Sprocket
- 31. Chain Assy
- 32. Joint Set
- 33. Retainer
- 34. Screw
- 35. Retainer
- 36. Bolt
- 37. Reverse Idle Shaft
- 38. Reverse Idle Gear
- 39. Bushing
- 40. Washer
- 41. Washer
- 42. Wave Washer
- 43. Circlip
- 44. Bolt
- 45. Plate

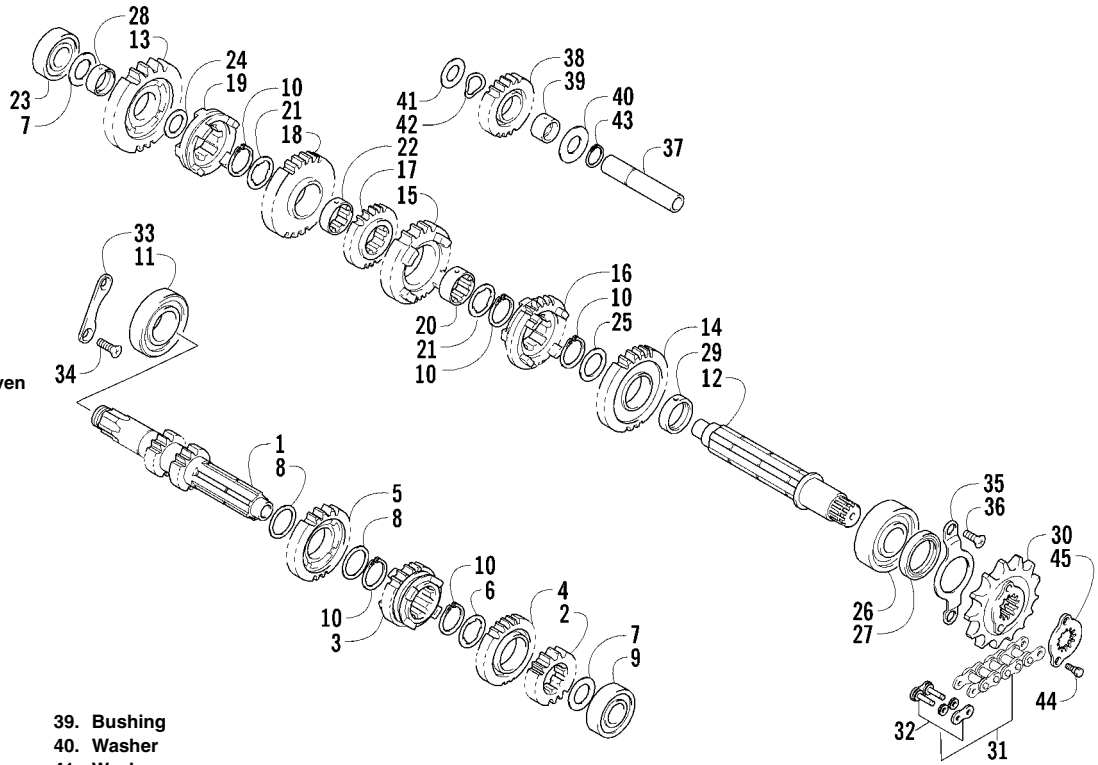

0739-226

1. In order, install the 2nd driven bushing, gear, washer, and circlip onto the driveshaft.



CC206D



CC207D

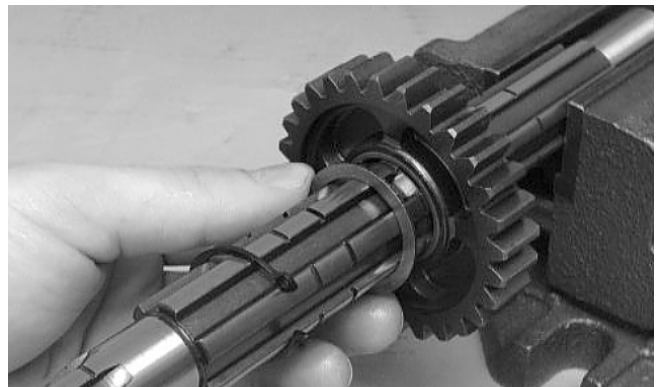

CC208D

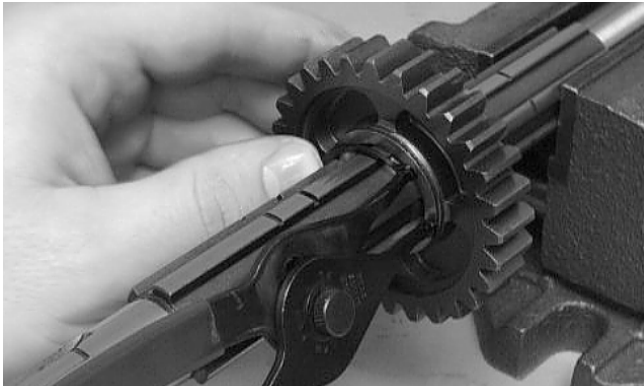

CC209D

2. Install the 4th driven gear onto the driveshaft.
3. Install the 3rd driven circlip, washer, and bushing onto the driveshaft. Make sure the oil hole in the bushing aligns with the hole in the shaft.

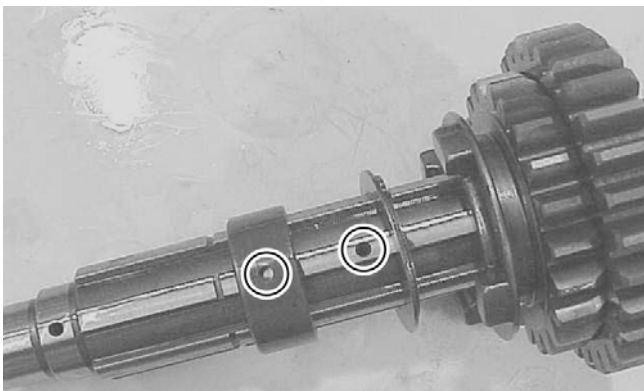

SP221

⚠ CAUTION

It is very important to assure the oil feed hole in the bushing and oil supply hole in the driveshaft align. If not aligned, engine damage will result.

4. Install the 3rd driven gear onto the driveshaft.

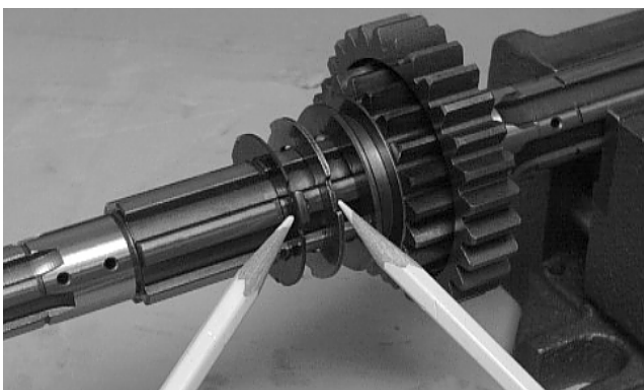

CC212D

5. Install the 5th driven gear onto the driveshaft.
6. In order, install the reverse driven bushing, reverse driven gear, washer, and circlip onto the driveshaft. Make sure the oil hole in the reverse driven bushing aligns with the hole in the driveshaft.

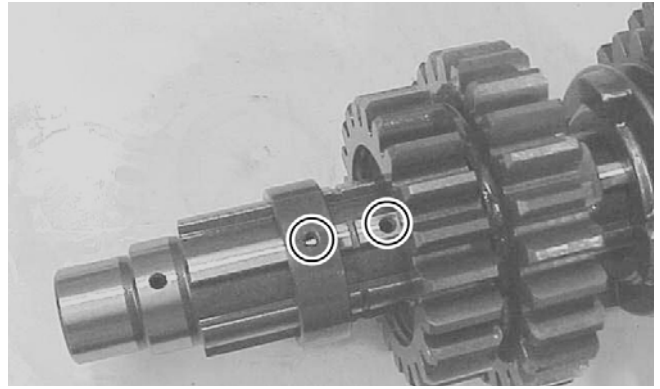

SP222

⚠ CAUTION

It is very important to assure the oil feed hole in the bushing and oil supply hole in the driveshaft align. If not aligned, engine damage will result.

7. Install the reverse dog onto the driveshaft making sure the four small dogs are facing toward the 1st driven gear as noted in disassembling.
8. Install the 1st driven washer (right side) onto the shoulder of the splined shaft; then install the 1st driven bushing and gear.

3



CC221D

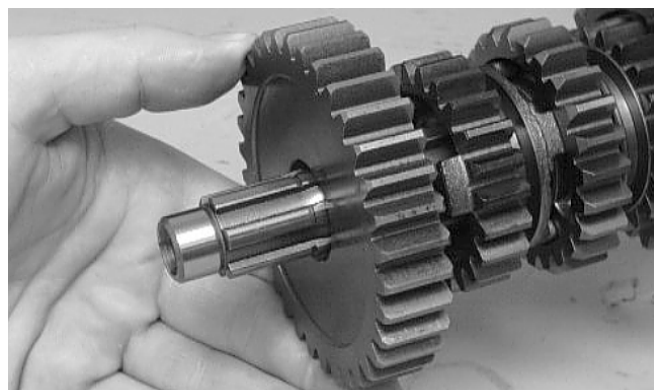

CC222D

9. Install the 1st driven washer (left side) on the driveshaft.

■ NOTE: The driveshaft is now completely assembled for installation.

COUNTERSHAFT

Disassembling

1. Remove the 2nd drive gear and washer from the countershaft.

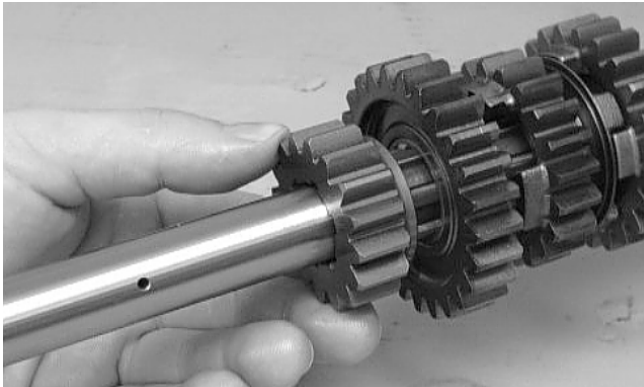

CC204D

2. Remove the 4th drive gear from the countershaft.

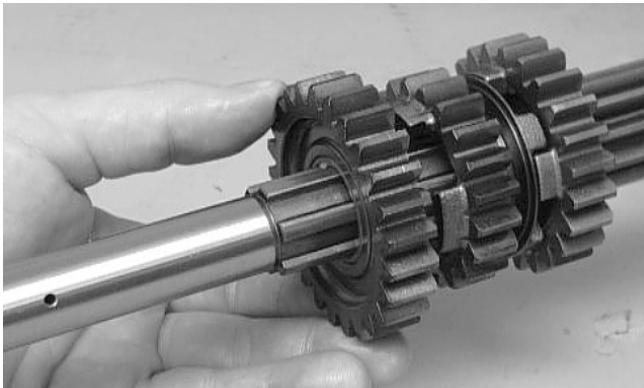

CC203D

3. Remove the 4th drive washer and 4th drive circlip from the countershaft.

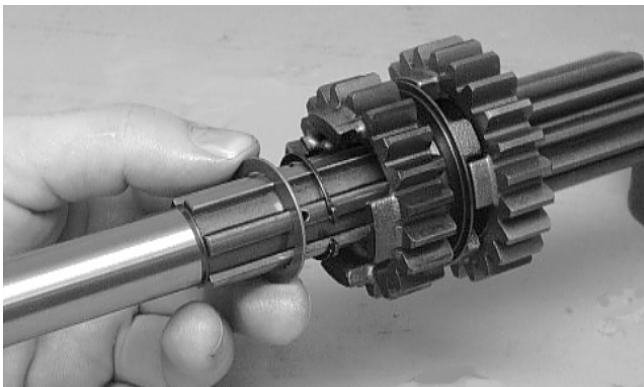

CC201D



CC200D

4. Remove the 3rd drive gear from the countershaft.
5. Remove the 5th drive circlip securing the 5th drive gear on the countershaft; then remove the first 5th drive washer and 5th drive gear.

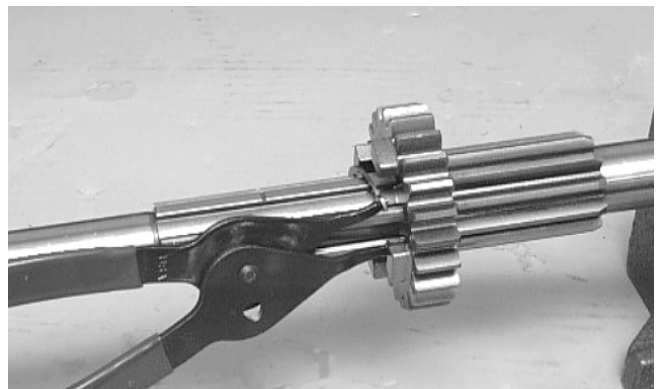

CC199D

6. Remove the remaining 5th drive washer from the countershaft.

Assembling

1. Install the first 5th drive washer onto the countershaft.
2. Install the 5th drive gear; then install the second 5th drive washer onto the countershaft. Secure with the circlip.

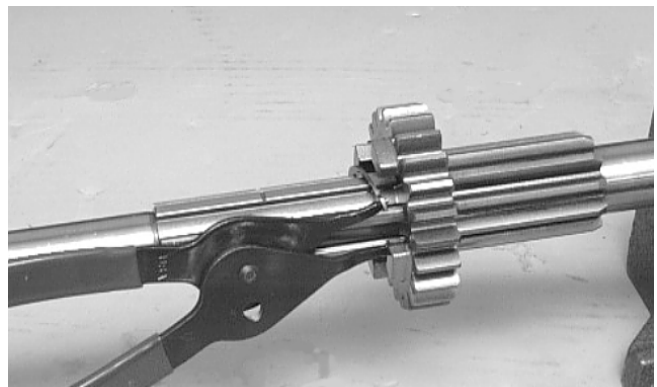

CC199D

3. Install the 3rd drive gear; then install the 4th drive circlip onto the countershaft.

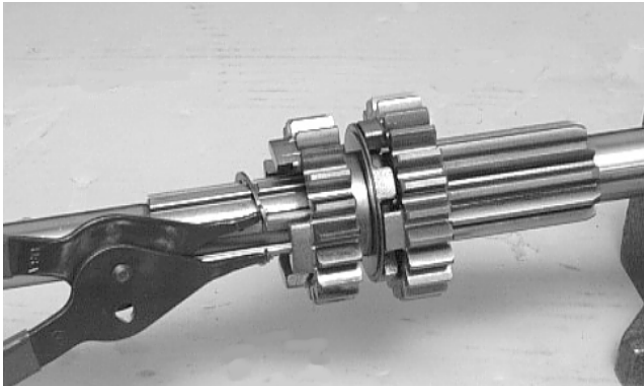

CC200D

4. Install the 4th drive washer and 4th drive gear onto the countershaft.

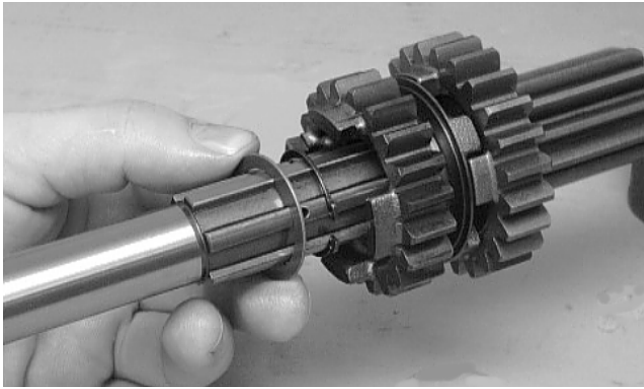

CC201D

5. Install the 2nd drive gear and washer onto the countershaft.



CC204D

■ **NOTE:** The countershaft is now completely assembled for installation.

Assembling Crankcase Half

■ **NOTE:** For ease of assembly, install components on the left-side crankcase half.

1. Install the left end of the crankshaft into the crankcase using the appropriate crankshaft installer tool.

■ **NOTE:** Never fit the crankshaft into the crankcase by striking it with a plastic mallet as the accuracy of the crankshaft alignment may be affected.

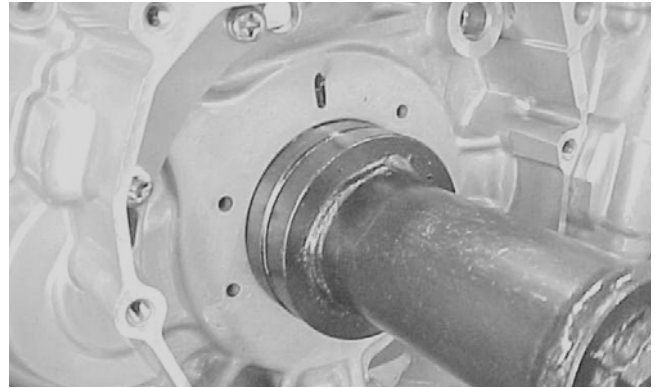

SP223

2. Install the crank balancer shaft.
3. Simultaneously, install the driveshaft and countershaft assemblies making sure the washer is on the countershaft.
4. Making sure the circlip is in position, install the reverse idler shaft; then install a washer, bushing, reverse idler gear, wave washer, and thrust washer.
5. Place each of the three shift forks into its respective gear or dog (1) (2) (3) as noted during disassembling.

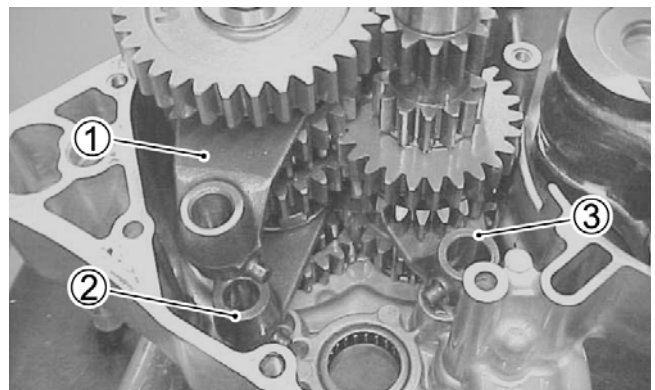

SP224

6. Install the shift cam (4); then install the shift fork shaft (5) and the reverse lock shaft (6).

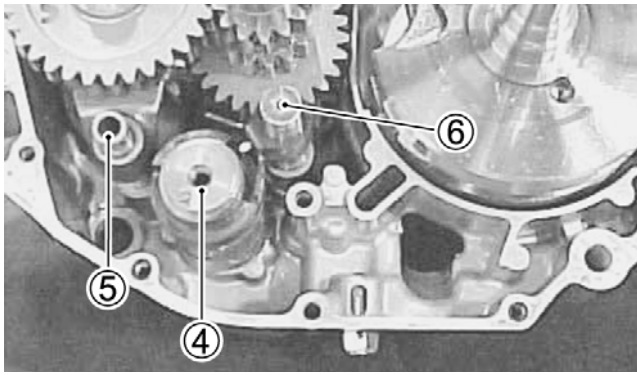

SP225

■ **NOTE:** Check to be sure that the gears all engage normally; then shift the transmission into neutral.

7. Verify that the two crankcase half alignment pins (1) are in place.

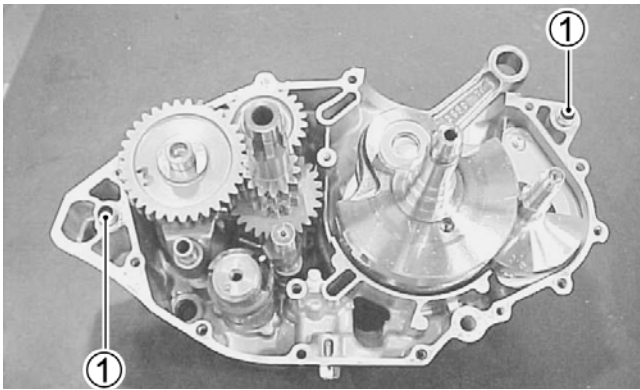

SP226

■ **NOTE:** Prior to joining crankcase halves, turn the shift cam to ensure all gears shift properly.

Joining Crankcase Halves

1. Verify that the washer is on the reverse idler shaft; then apply Three Bond Sealant (p/n 0636-070) to the mating surfaces. Place the right-side half onto the left-side half.

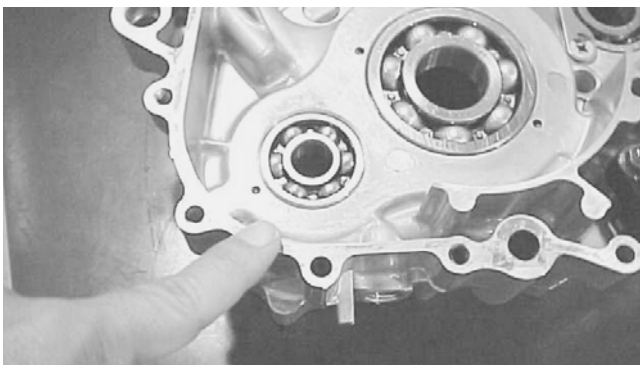

SP227

2. Using a plastic mallet, lightly tap the case halves together until cap screws can be installed.
3. From the left side, install the six case half cap screws; then tighten only until snug.

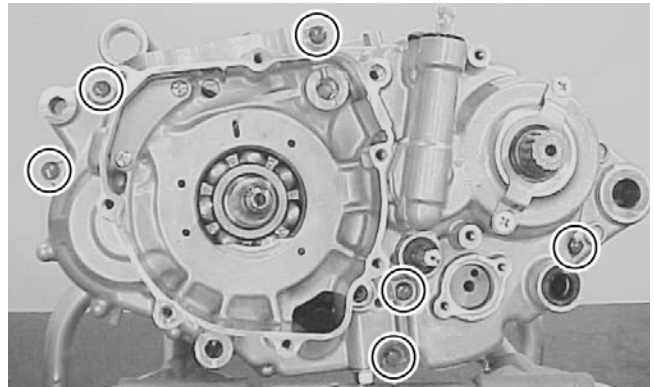

SP228

■ **NOTE:** Rotate the shafts back and forth to ensure no binding or sticking occurs.



SP230

4. From the right side, install the eight case half cap screws (three inside the case); then tighten only until snug.

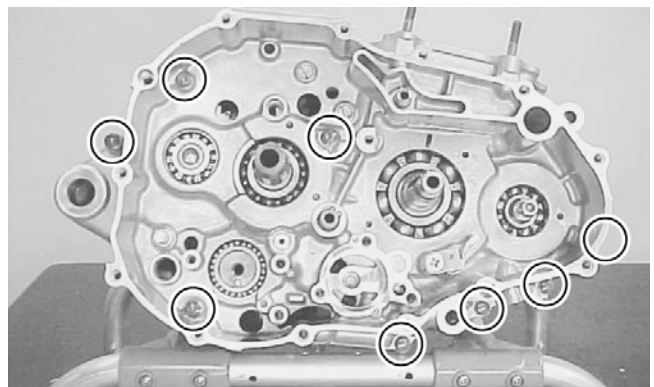

SP229

■ **NOTE:** Rotate the shafts back and forth to ensure no binding or sticking occurs.

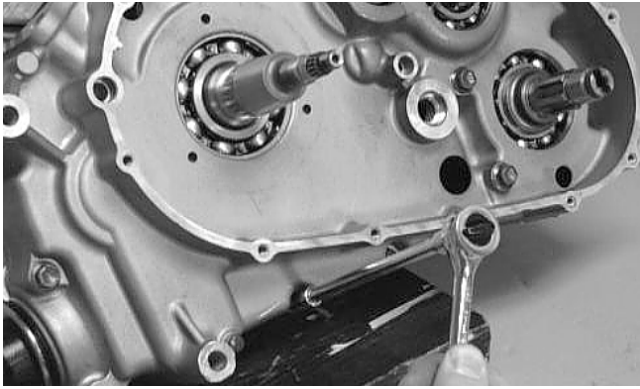

CC095D

5. In a crisscross/case-to-case pattern, tighten the cap screws (from steps 3-4) until the halves are correctly joined; then tighten to specifications.

■ **NOTE:** Rotate the shafts back and forth to ensure no binding or sticking occurs.

Installing Right-Side Components

- A. Primary Drive Gear
- B. Crank Balancer Gear

■ **NOTE:** It will be necessary to install the starter driven gear, starter one-way clutch, and the rotor/flywheel on the left side prior to installing right-side components. This is done to provide a means of holding shafts for tightening right-side shaft nuts.

1. Install the starter driven gear (1) and the key (2); then clean any oil or grease from the tapered portion of the crankshaft and from inside the rotor/flywheel tapered bore.

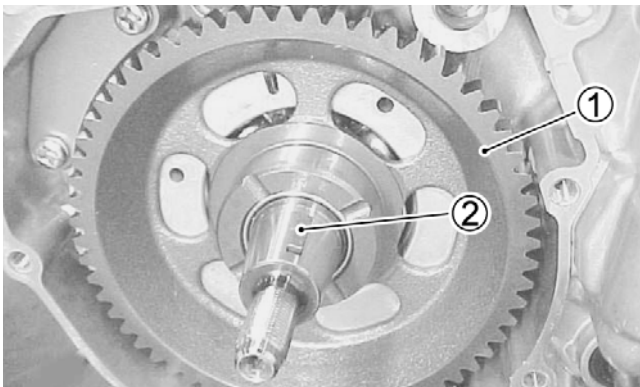

SP231

2. Align the keyway with the key and install the rotor/flywheel; then using an offset 27 mm wrench, hold the flywheel and tighten the nut to specifications.



SP232

3. Install the pins (1); then install the crank balancer drive gear (2). Install the key (3) and cam chain drive sprocket (4).

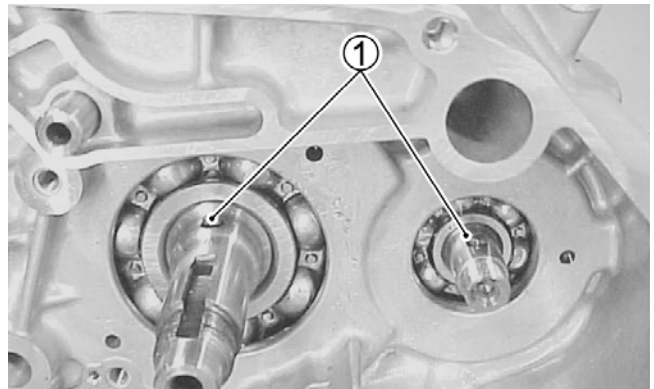

SP233

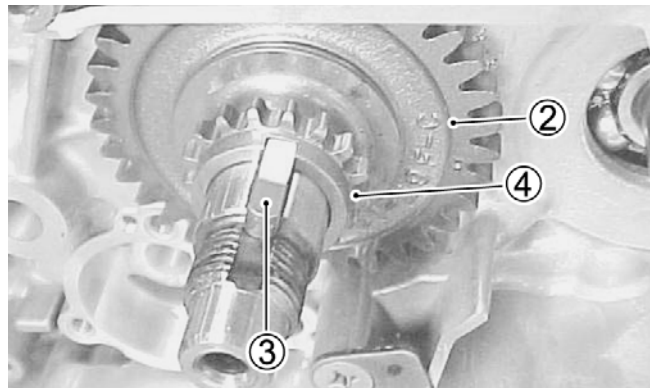

SP234

4. Apply engine oil to the threads; then install the primary drive gear nut and tighten to specifications.

3



SP235A

5. Install the crank balancer driven gear (5) aligning the timing marks (6); then holding the generator rotor with a 27 mm offset wrench, tighten the crank balancer driven gear nut to specifications.

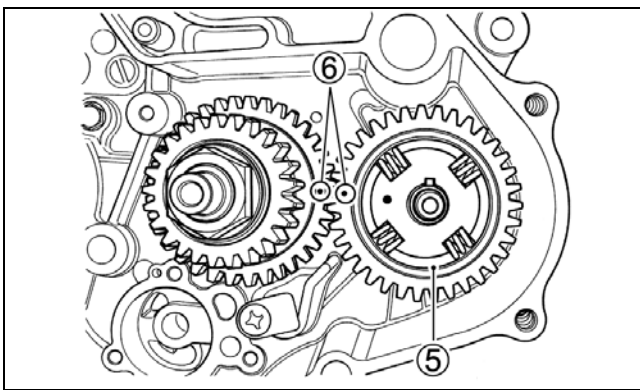

ATV2169

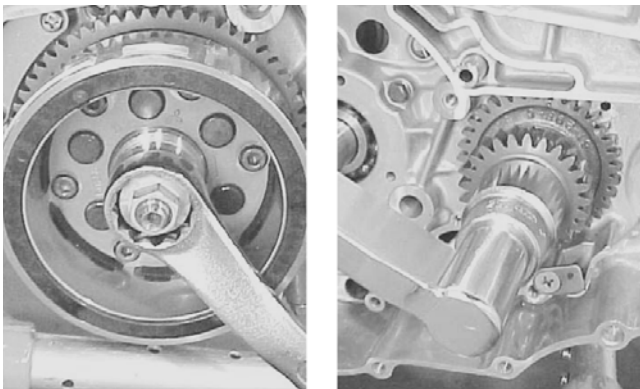

SP236A

C. Shift Cam Driven Gear
D. Oil Pump
E. Cam Chain

■ **NOTE:** Steps 1-5 in the preceding sub-section must precede this procedure.

6. Install the shift cam driven gear bolt and tighten to specifications.

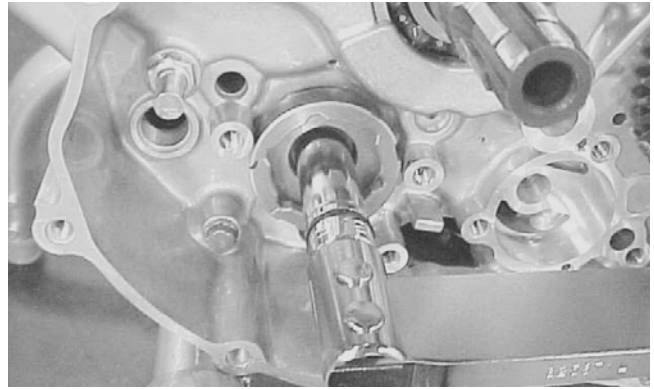

SP237

7. Install each pawl lifter into the shift cam driven gear with the large shoulder (A) directed to the outside; then apply a small amount of red Loctite #271 to the pawl lifter screws and tighten them securely.

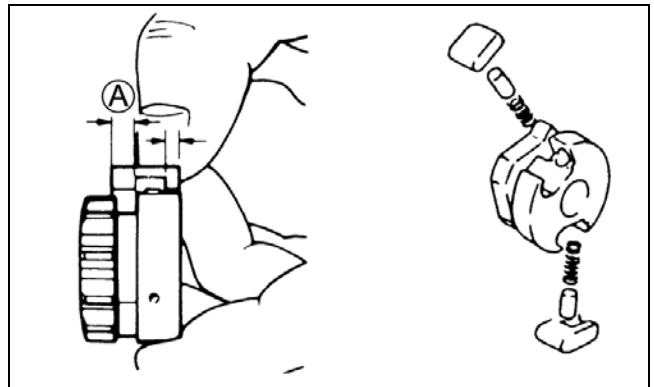

ATV2170A

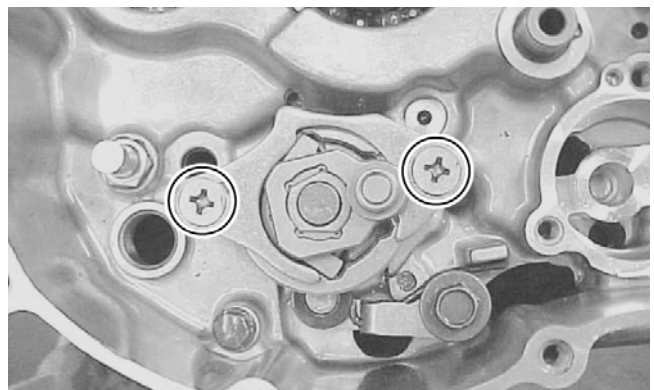

SP242

8. Apply engine oil to the moving parts of the oil pump and all mating surfaces.

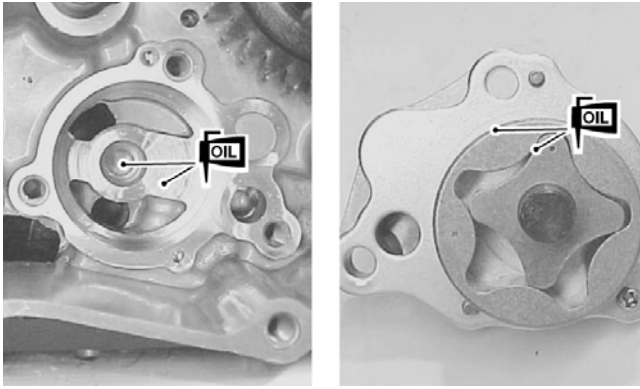

SP238A

9. Apply red Loctite #271 to the oil pump mounting screws and tighten securely; then install the oil pump driven gear aligning the pin (1) with the groove (2) and install the circlip.

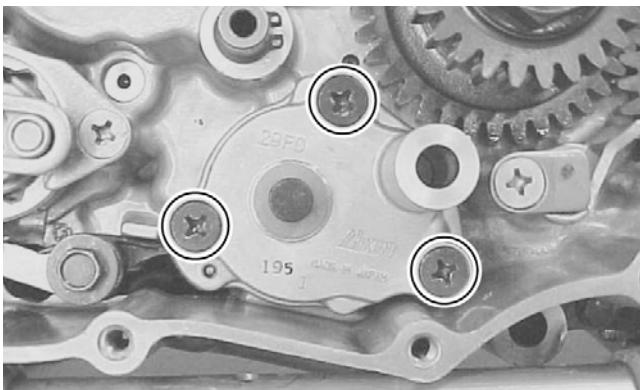

SP240

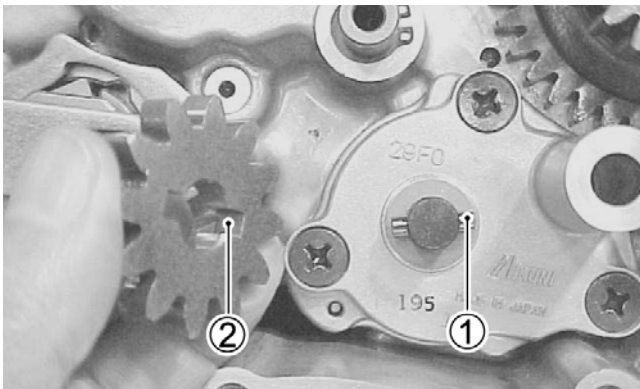

SP241

10. Install the cam chain (1) onto the sprocket; then install the cam chain tensioner and tighten the mounting bolt (2) to specifications.

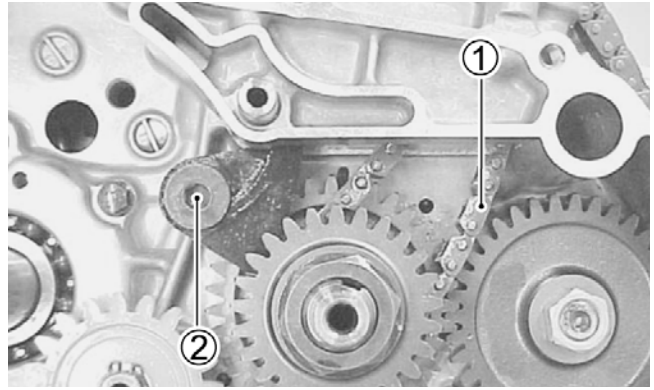

SP251

F. Oil Pipe G. Clutch

- **NOTE:** Steps 1-10 of the preceding sub-section must precede this procedure.

3

11. Apply engine oil to the O-rings on the oil pipe; then install and tighten the hold-down bolt securely.

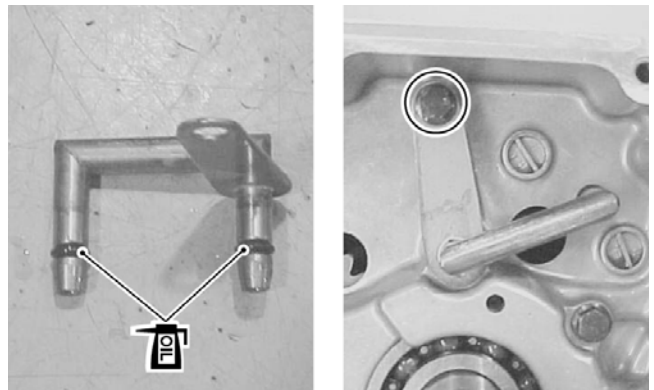

SP243A

12. Install the spacer (3), primary driven gear assembly (1), washer (2), clutch sleeve hub (4), lock washer (14), and clutch sleeve hub nut (13) on the driveshaft.

KEY

- | | |
|------------------------|----------------------|
| 1. Primary Driven Gear | 17. Release Pin |
| 2. Washer | 18. Camshaft |
| 3. Spacer | 19. Release Arm |
| 4. Sleeve Hub | 20. Washer |
| 5. Drive Plate #1 | 21. Bearing |
| 6. Drive Plate #2 | 22. Bearing |
| 7. Driven Plate | 23. Seal |
| 8. Pressure Disc | 24. Cap Screw |
| 9. Spring | 25. Camshaft Stopper |
| 10. Bolt | |
| 11. Washer | |
| 12. Bearing | |
| 13. Nut | |
| 14. Lock Washer | |
| 15. Push Rod | |
| 16. Retainer | |

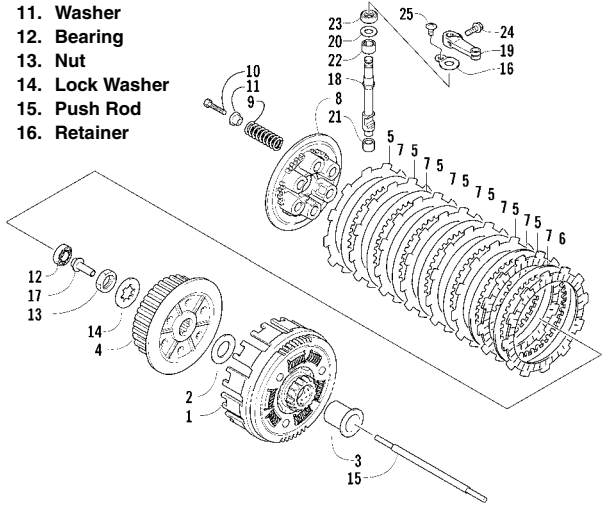

0739-225

13. Using the special holding tool, hold the clutch sleeve hub and tighten the clutch sleeve hub nut to specifications.

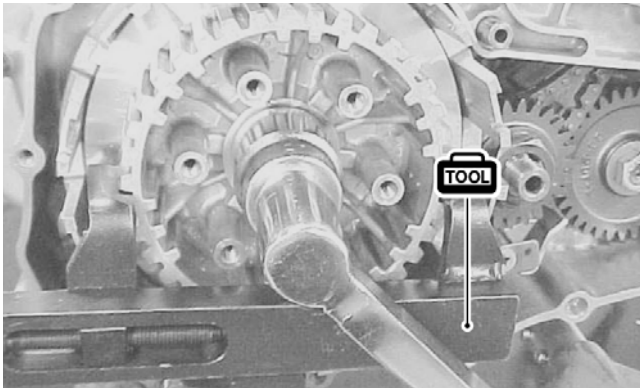

SP245

14. Bend the washer over securely engaging the flat of the nut.

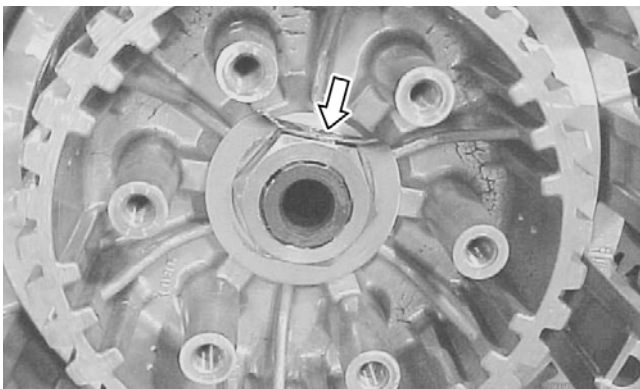

SP246

15. Install the drive and driven plates one by one into the clutch hub sleeve in the prescribed order.

■ **NOTE:** Be sure to install the drive plate with the inside diameter of 122.5 mm (4.82 in.) first. Two different types of drive plates are used. They are the one with the 122.5 mm (4.82 in.) inside diameter and seven with an inside diameter of 116.0 mm (4.5 in.).



SP247

16. Referring to the illustration, install the clutch push rod (15) and clutch release pin (17) and bearing (12); then install the pressure disc (8) and tighten the clutch spring set bolts in stages using the illustrated pattern.



SP248

17. Install the alignment pins (1) and a new gasket (2); then install the clutch cover using a new washer gasket at position (1). Tighten the cap screws securely.

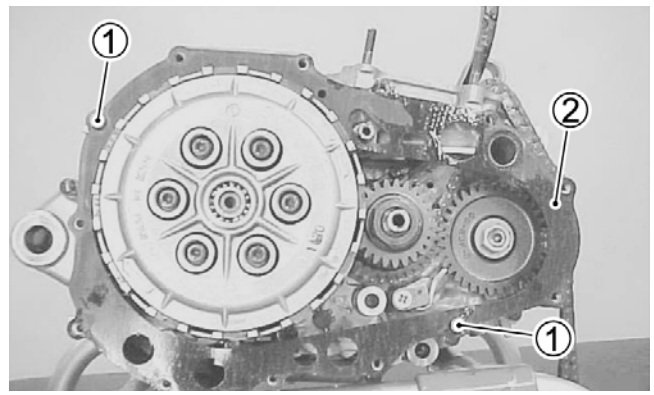

SP249

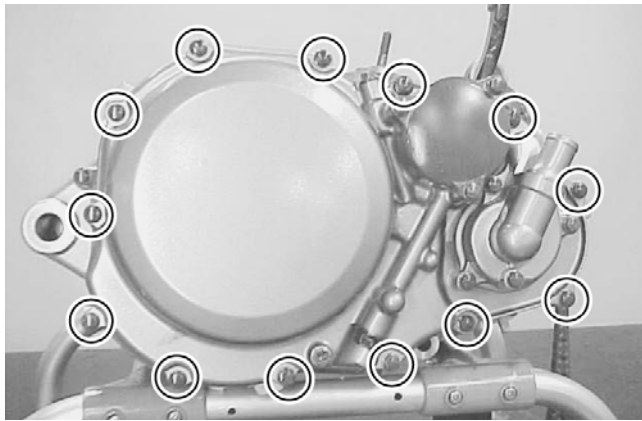

SP250

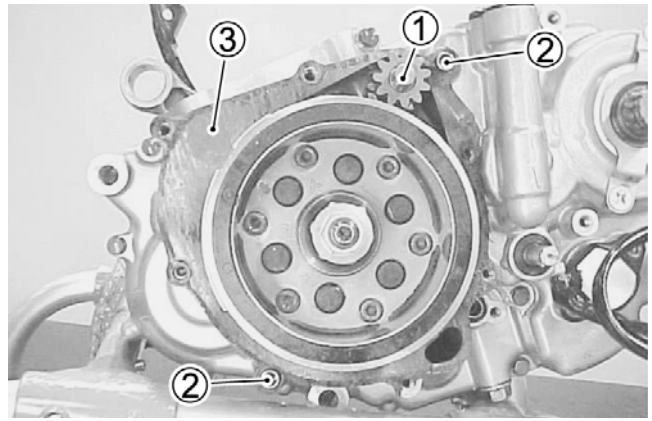

SP254

Installing Left-Side Components

- A. Neutral Switch**
- B. Starter Driven Gear**

1. Install the springs (1), contacts (2), and a new O-ring (3); then install the neutral switch and tighten the Allen-head cap screws to specifications.

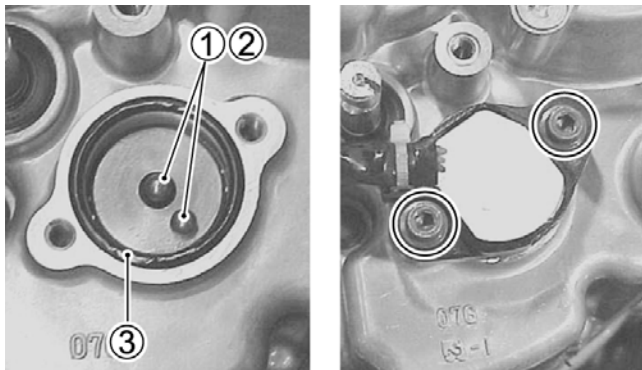

SP252A

2. Install the starter driven gear (1), dowel pins (2), and a new gasket (3); then install the cover and tighten the cap screws securely.

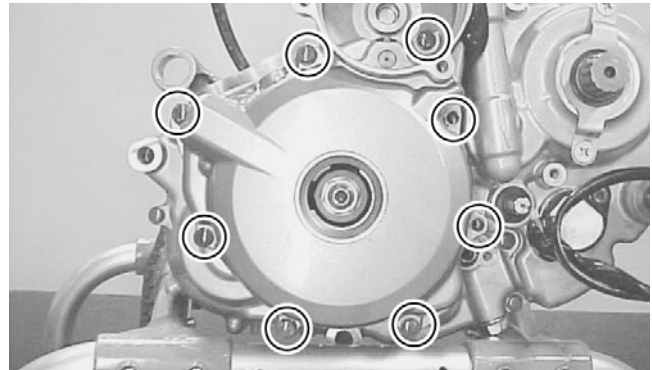

SP255

3

Installing Top-Side Components

- A. Piston**
- B. Cylinder**

■ **NOTE:** If the piston rings were removed, install them in this sequence.

1. Install the spacer (3) into the oil ring groove, then install the two side rails (4).

■ **NOTE:** The spacer and side rails do not have a top and bottom designation. Do not allow the spacer ends to overlap. B is correct.

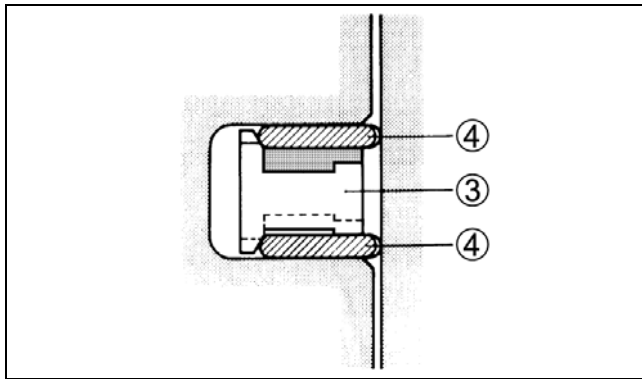

ATV2173

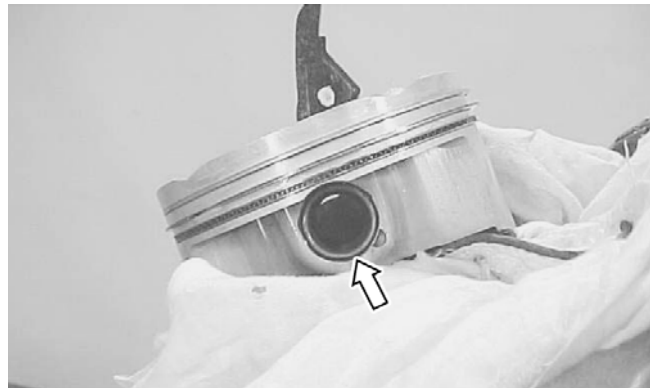

SP256

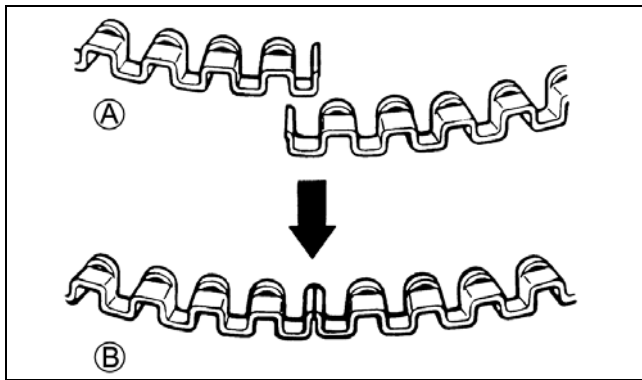

ATV2174

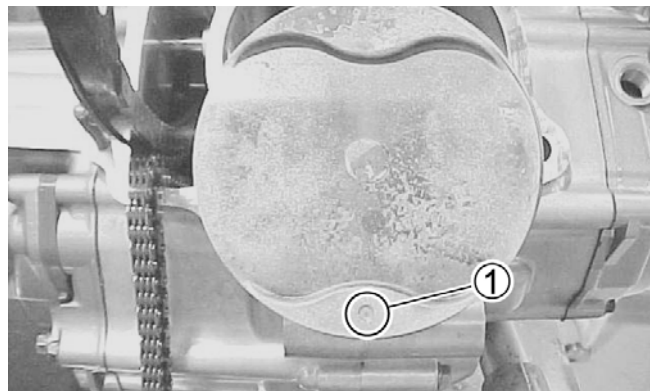

SP257

■ **NOTE:** The first (1) and second (2) rings differ in shape. Install the rings with the mark directed up.

2. Install the second ring (2); then install the first ring (1).

5. Apply engine oil to the sliding surface of the piston and the big end of the connecting rod; then install the alignment pins (2) and a new gasket (3) onto the crankcase.

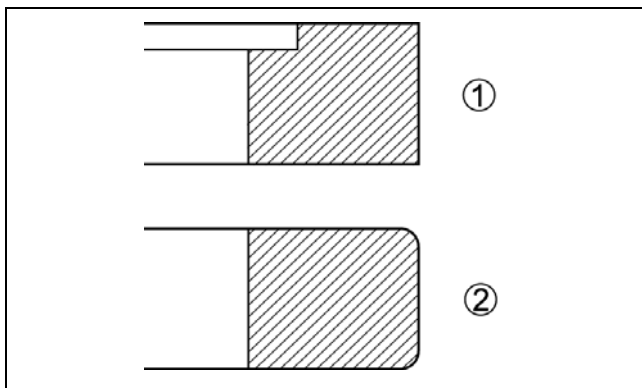

ATV2175

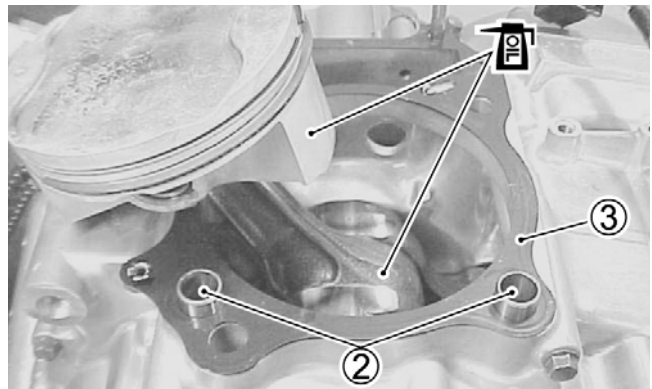

SP258

3. Apply engine oil onto the piston pin and the small end of the connecting rod.
4. Place a clean rag over the cylinder base to prevent the piston-pin circlip from dropping into the crankcase; then install the piston, piston pin, and a new circlip with the punch mark (1) on the piston directed toward the exhaust side.

6. Position each piston ring correctly and work the cylinder down onto the piston making sure the rings do not catch on the cylinder skirt.

■ **NOTE:** To correctly position the end gaps with (A) being the exhaust, position (5) is the 2nd ring and lower side rail, position (6) is the upper side rail, and position (7) is the 1st ring and spacer.

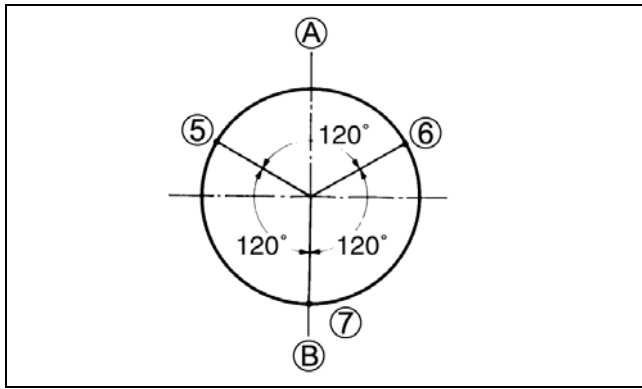

ATV2176

■ **NOTE:** When mounting the cylinder after installing the camshaft drive chain, be sure to keep the drive chain taut. The drive chain must not be allowed to catch between the cam drive chain sprocket and the crankcase when the crankshaft is rotated.



SP259

7. Install the cam chain guide (1) ensuring that the guide is installed properly; then install the alignment pins (2) and a new gasket (3).

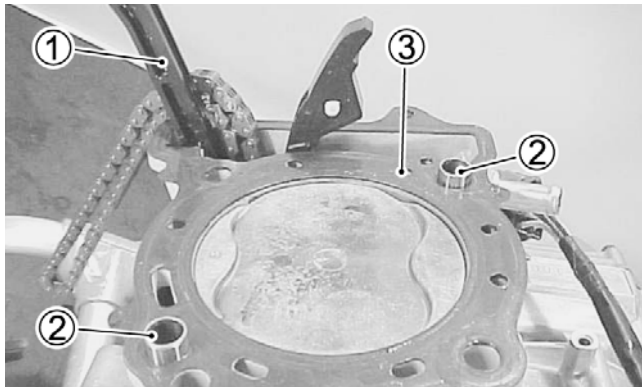

SP260

■ **NOTE:** Always use a new cylinder head gasket to prevent leakage.

C. Cylinder Head
D. Camshafts
E. Valve Cover
F. Cam Chain Tensioner

■ **NOTE:** Steps 1-7 of the preceding sub-section must precede this procedure.

8. Install the cylinder head on the cylinder.
9. Lightly oil the threads of the 10 mm cap screws and the washers; then install and tighten in two steps to specifications using a diagonal pattern.

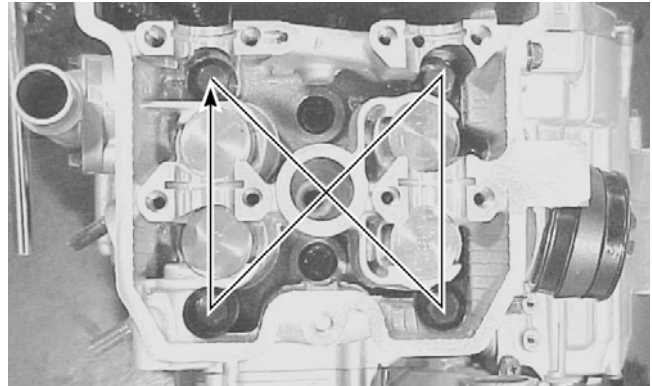

SP261

10. Tighten the two 6 mm cap screws (1) and cylinder nuts (2) to specifications.

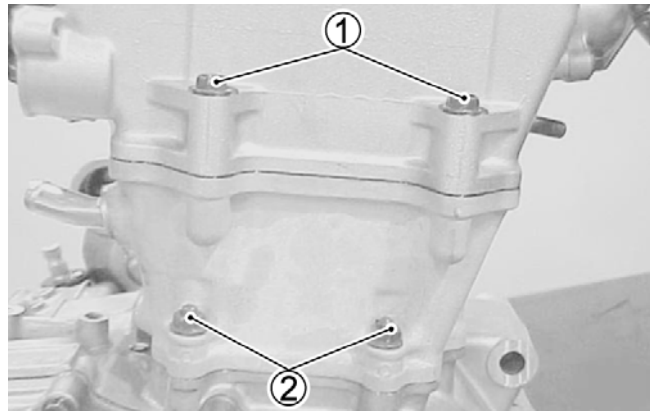

SP262

11. Turn the rotor/flywheel until the "T" line on the rotor is aligned with the center of the timing hole in the cover.

■ **NOTE:** If the crankshaft is turned without holding the cam chain taut, the chain will catch between the crankcase and the cam chain drive sprocket.

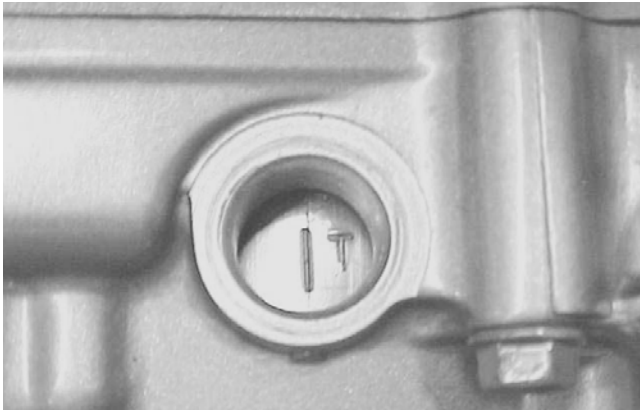

SP263

12. Apply molybdenum oil solution to the camshaft journals, camshaft lobes, and the camshaft journal holders; then place each camshaft into the correct position.

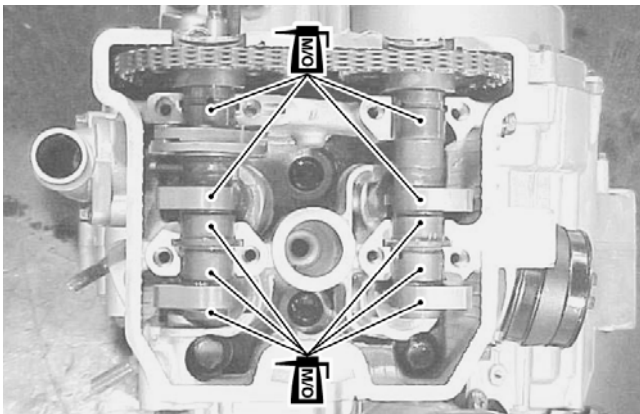

SP264

13. With the "T" line centered in the timing hole, hold the camshaft steady and pull up the cam chain to remove any slack; then turn the exhaust camshaft so the arrow (1) is aligned with the gasket surface of the cylinder head.
14. Engage the cam chain with the exhaust camshaft sprocket.
15. Starting at the roller pin directly above the arrow (2), count out 15 pins toward the intake camshaft; then align and engage the arrow (3) with the 15th pin.

■ **NOTE:** The cam chain should now be on all three sprockets. Be careful not to rotate the crankshaft until the camshaft journals and cam chain tensioner are secured.

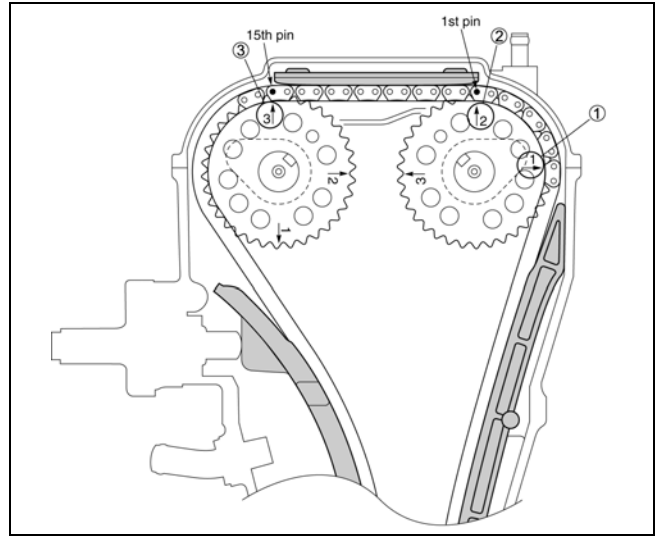

ATV2177

16. Install the alignment pins (1) and cam chain guide; then install the camshaft journal holder marked EX on the exhaust camshaft and the camshaft journal holder marked IN on the intake camshaft.

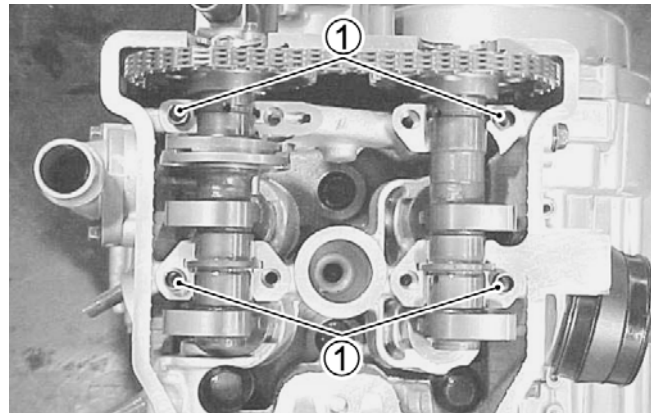

SP265

17. Making sure that the piston position is top-dead-center on the compression stroke, tighten the camshaft journal holder cap screws to specifications.

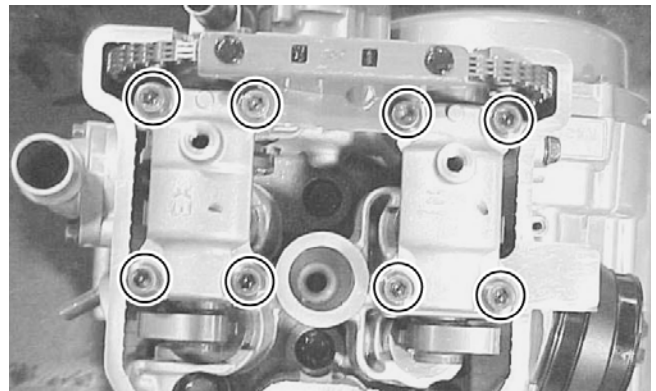

SP266

18. Apply engine oil to the tensioner push rod; then depress the ratchet mechanism (1) and depress the tensioner push rod (2) all the way into the tensioner housing.

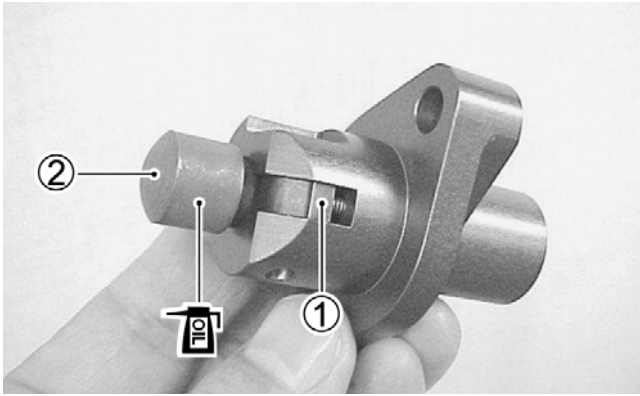

SP267

19. Install a new gasket and the cam chain tensioner assembly into the cylinder making sure the UP stamp is directed towards the cylinder head.
20. Tighten the cam chain tensioner Allen-head cap screws to specifications; then install the tensioner spring (3) and tighten the spring holder plug to specifications.

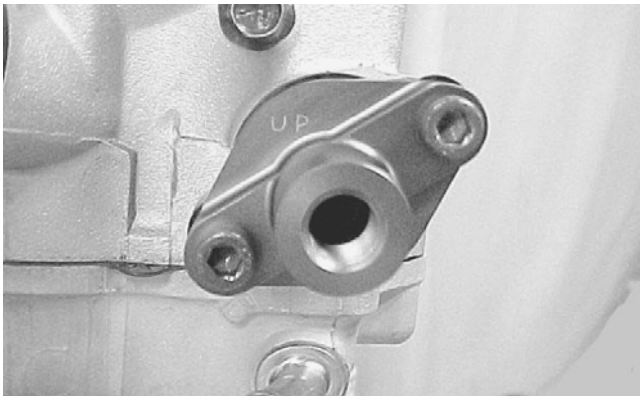

SP268



SP269

21. Adjust the valve clearance at this time. See Section 2.
22. Wipe all oil from the mating surfaces of the valve cover and cylinder head; then apply Three Bond Sealant (p/n 0636-070) to the mating surfaces.
23. Apply engine oil to both sides of the washers (1); then lightly tighten the valve cover in two steps to specifications in a diagonal pattern.

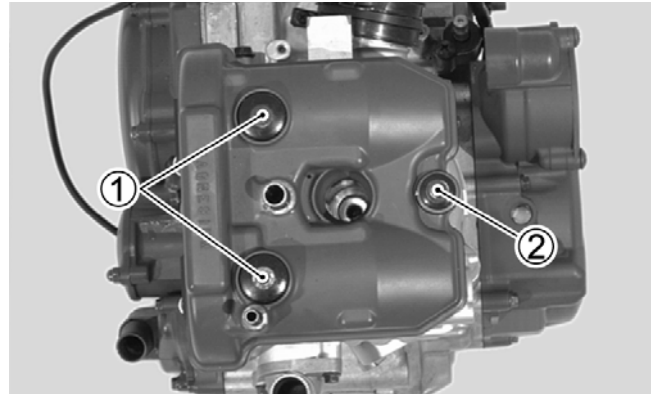

SP270

Installing Engine/Transmission

3

■ **NOTE:** Arctic Cat recommends that new gaskets and O-rings be installed whenever servicing the ATV.

1. From the left side, place the engine/transmission into the frame.
2. Install the mounting fasteners securing the engine/transmission in the following sequence.
 - A. Lower rear: One cap screw and nut with two spacers. Tighten only until snug.
 - B. Upper rear: Loosely fasten the engine mount-to-frame cap screws; then install the cap screw w/nut and flat washer. Tighten only until snug.
 - C. Lower front: One cap screw, nut, spacer, and washer. Tighten only until snug.
 - D. Upper front: Two cap screws (inside the bracket) and one cap screw and nut (topside of engine). Tighten only until snug.

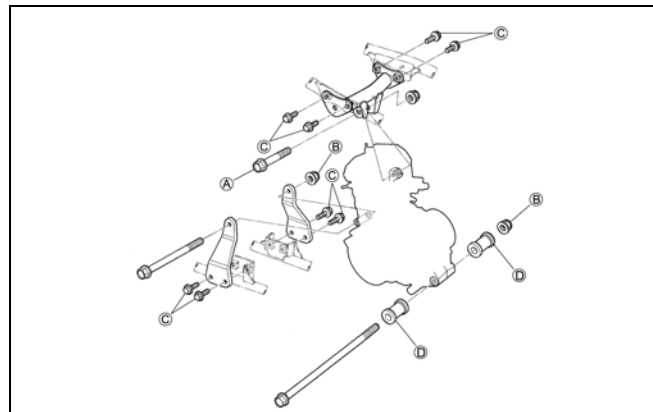

ATV2178

3. Tighten the engine mounting fasteners to the specifications.

A. Lower rear and lower front.

B. Upper front (inside the bracket) and upper front (topside of engine).

C. Upper engine mount-to-frame cap screws and engine to engine mount cap screw with nut and flat washer.

4. Install the exhaust pipe and muffler; then tighten the exhaust pipe nut (1), muffler mounting bolts (2), and the connector bolt (3) to specifications.

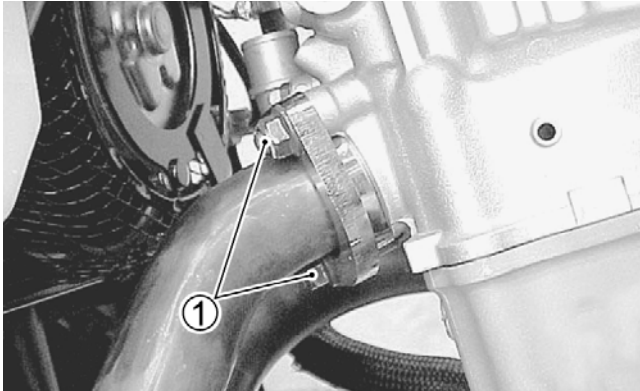

SP271

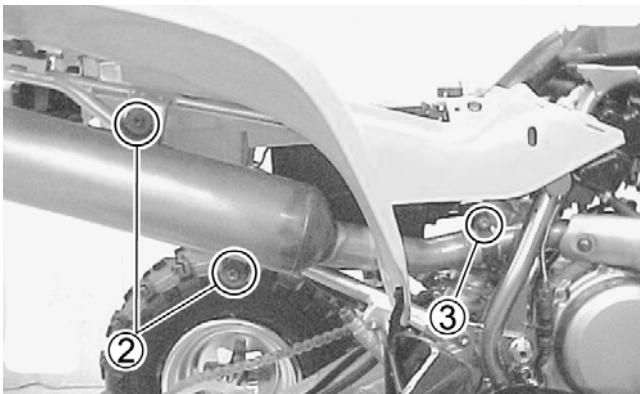

SP272

5. Install the engine sprocket with drive chain noting marking (A) on the sprocket; then apply red Loctite #271 to the threads and tighten the cap screws to specifications.

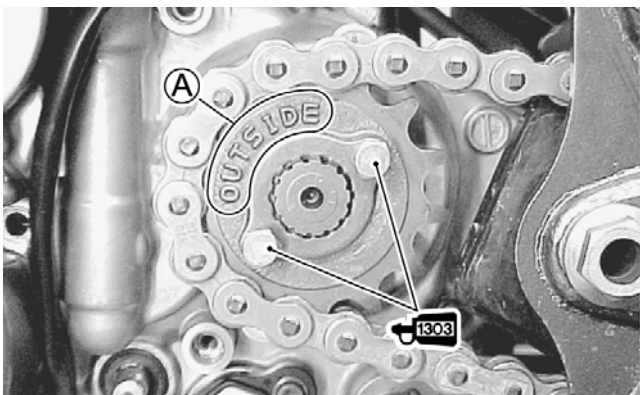

SP273

6. Install the engine coolant hose; then install the spacer (1) with O-ring to the engine oil outlet pipe and tighten the cap screws (2) securely.

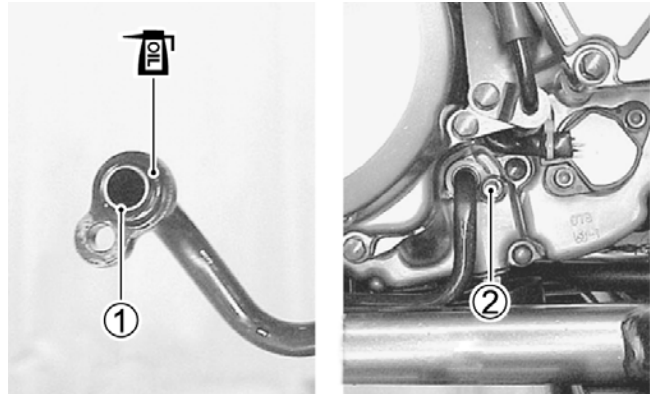

SP274A

7. Install the engine oil union bolt and tighten to specifications.

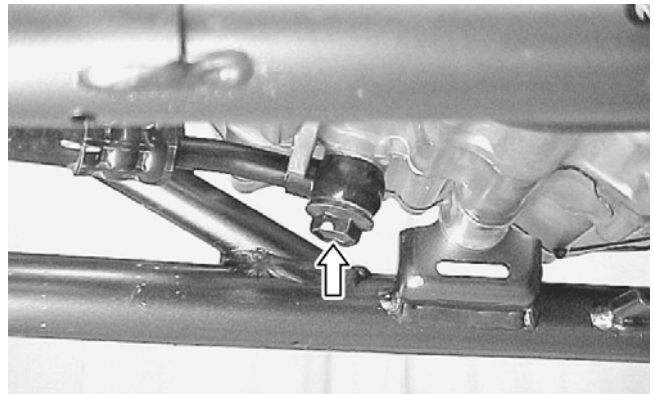

SP276

8. Join the wiring connectors to the alternator lead wire coupler (3) and the neutral start lead coupler (4); then connect the starter cables.

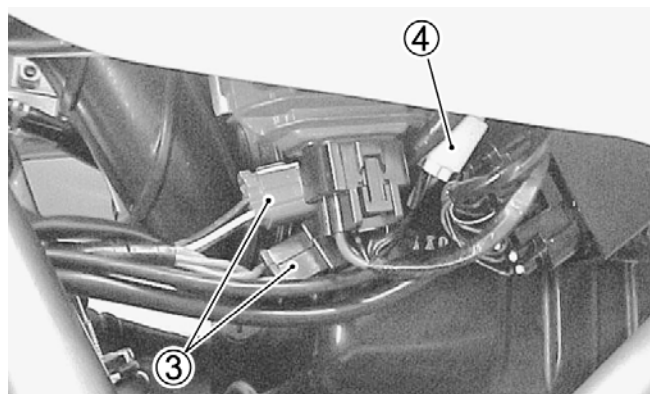

SP277

9. Connect the reverse gear selector cable (6); then install the cable bracket (5).

10. Install the clutch cable to the clutch actuator lever.

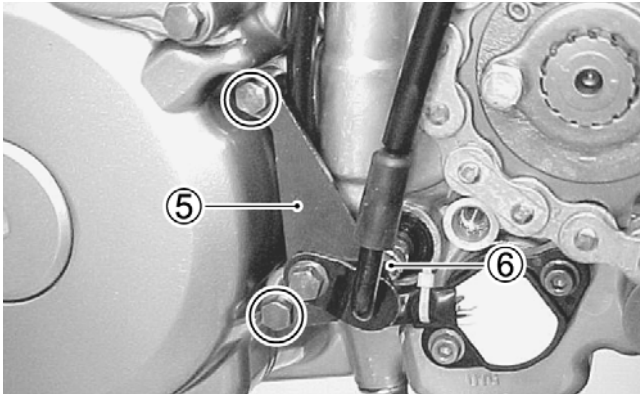

SP278

11. Install the carburetor and tighten the clamps securely.
12. Install the spark plug cap, engine sprocket cover, oil drain, tank, and breather hose; then install the gas tank and body.

13. Fill the oil tank. See Section 2.
14. Fill the cooling system with the appropriate mix of Arctic Cat anti-freeze and water. See Section 2.
15. See Section 2 for all adjustments.
16. Connect all remaining electrical connections; then install the battery making sure to connect the positive battery cable first and the negative cable last.
17. Install the seat making sure it “locks” into position.

⚠ CAUTION

If the engine had a major overhaul or if any major part was replaced, proper engine break-in procedures must be followed (see Section 1). If the proper engine break-in procedures are not followed, severe engine damage may result.

NOTES